

# INSTALLATION GUIDELINES 2017

SUPERMARKET FOOD HALLS

gerflor.com

INSTALLATION GUIDELINES



PLEASE REFER TO YOUR GERFLOR LOCAL CONTACT



**Gerflor**<sup>®</sup>  
the flooring group

# CONTENTS

## **ATTRACTION® / GTI / GTI MAX**

1. Scope of use .....	page 4
2. Surface preparation .....	page 6
3. Installation .....	page 11
4. Finishing and junctions .....	page 17
5. Laying TBS self-adhesive strips .....	page 19
6. Final cleaning .....	page 20
7. Replacing furniture .....	page 21
8. Repairs and maintenance .....	page 21
9. Entrance MAT incorporating ROMAT GT from ROMUS .....	page 22

## **GTI / GTI MAX CONTROL**

1. Scope of use .....	page 25
2. Surface preparation .....	page 27
3. Installation .....	page 32
4. Finishing and junctions .....	page 35
5. Laying TBS self-adhesive strips .....	page 37
6. Final cleaning .....	page 38
7. Replacing furniture .....	page 39
8. Repairs and maintenance .....	page 39
9. Entrance MAT incorporating ROMAT GT from ROMUS .....	page 40

## **TARASAFE X-TRA**

Introduction .....	page 43
1. Scope of use .....	page 45
2. Surface preparation .....	page 45
3. Installation .....	page 47
4. Finishing and junctions .....	page 53
5. Final cleaning .....	page 57
6. Replacing furniture .....	page 57
7. Repairs and maintenance .....	page 57

## **CREATION CLIC 70**

1. Scope of use .....	page 59
2. Surface preparation .....	page 60
3. Installation .....	page 60
4. Finishing and junctions .....	page 64
5. Final cleaning .....	page 67
6. Replacing furniture .....	page 67
7. Repairs and maintenance .....	page 68
8. Entrance MAT incorporating ROMAT GT from ROMUS .....	page 69

**IMPORTANT** : The information in this document is valid from: 01/01/2017 and is subject to change without notice. In the face of continuous technical improvements, before starting any work, our customers should check with us that this document is still in force.

ATTRACTION® / GTI / GTI MAX



ATTRACTION®  
GTI  
GTI MAX

---

# ATTRACTION® / GTI / GTI MAX

## 1

## SCOPE OF USE

SALES AREA	TYPE OF PRODUCTS SOLD IN THESE AREAS	CONDITIONS
PRACTICAL	Small DIY, car, luggage	<ul style="list-style-type: none"> <li>- Pedestrian traffic</li> <li>- Trolleys</li> <li>- Manual forklift</li> <li>- Electric forklift operated by a driver capacity 1300kg</li> </ul>
CLEANING	Laundry, cleaning products, multi-use, deoderants, bins, haberdashery, brushes	
GROCERY	Sweets, biscuits, crisps, tinned goods, carbohydrates	
HOUSEHOLD	Kitchen, decoration, household linen, crockery, cooking, small and large electrical goods	
PETS	Food, health, accessories	
DRINKS	Fruit juices, water, beers, sodas	
WINE/ SPIRITS	Wine, spirits, champagne	
STORAGE	-	
SEASONAL EVENTS	Offers and promotions	
FRESH	Butter, cream, cheese, eggs, yoghurts, milk	

### INTRODUCTION – CONDITIONS FOR USE

	INDENTATION (P) RATING FOR NEW AND RENOVATED AREAS		TEMPERATURE CONSIDERATIONS	PERIPHERAL EXPANSION
ATTRACTION® GTI UNI GTI PURE DECOR	U4P4	P3 areas that also have to bear heavy wheeled traffic within the limits shown below. Cleaning is limited to, at most, a powered floor cleaner.	Since these shops are climate-controlled, the floor covering is not subject to temperature differences of more than 20°C. The dimensional stability of Attraction®/GTI/ GTI Max tiles allows loose laying up to 500m².	Since the buildings are temperature controlled all year round, GERFLOR recommends an edge clearance of 5mm.
GTI MAX DECOR	U4P4S	P4 areas that also have to bear heavy mobile or static loads. Cleaning is limited to, at most, a powered floor cleaner.		



## 1 SCOPE OF USE

### INTRODUCTION – CONDITIONS FOR USE

	RESISTANCE TO STATIC LOADS
	MAXIMUM PRESSURE
ATTRACTION® GTI UNI GTI PURE DECOR	< 40 kg / cm <sup>2</sup>
GTI MAX DECOR	< 50 kg / cm <sup>2</sup>

### GERFLOR GTI TILES ARE SUITABLE FOR THE TRAFFIC OF MANUAL AND ELECTRIC PALLET TRUCKS

#### Precautions for electric pallet trucks:

1. Choose models with speed controller
2. Preferably use polyurethane wheels
3. Ask the manufacturer's technicians to adjust 3 important settings depending on the loads transported:
  - Max speed
  - Acceleration speed
  - Deceleration speed

#### Recommended pallet truck models:

- BT TOYOTA : - Electric: BT Levio W range, LWE140, 160, 180, 200 models  
- Manual: BT Lifter range
- STILL : - Electric: EXU range, EXU 16, 18, 20, 22 models  
- Manual: HPT or HPS range
- FENWICK : - Electric: T16, T18, T20 models

TYPE OF USE	Electric pallet truck with controller
TYPE OF WHEELS	Polyurethane wheels (for example, Vulcolan)
STANDARD SPEED 6 KM/H	Recommended standard speed: 80% of max permitted = 4.8 km/h
LOAD WEIGHT: UP TO 1,500 KG INCLUDED	OK
LOAD WEIGHT UP TO 2,000 KG	Marking effect
LOAD WEIGHT > 2,000 KG	Burn effect
STATIC LOAD	No limit
DYNAMIC LOAD	OK up to 2,000 kg of load on pallet truck

#### Heavy pallets (water) placed on shelves

Burn in case of acceleration of the pallet truck at stop position

\*heaviest load in supermarket = 1,200 kg (1 pallet of water)

## 2 SURFACE PREPARATION

The aim of these instructions is to serve as a reminder to those concerned with the inspection, acceptance and preparation tasks that must be completed before the installation of thin floorcoverings in supermarket food halls.

### 1. New floor surfaces and preparation of hydraulic concrete surfaces

Taken from NF P62-203 (DTU 53.2)

#### 1.1 TYPES OF NEW FLOOR SURFACE

SURFACE TYPE
Flooring on a direct to earth platform
Floor on a flat slab using poured concrete with continuous bearing surfaces
Floor on a flat slab using preformed concrete shuttering slabs and poured concrete with continuous bearing surfaces
Floors made from cellular reinforced concrete slabs with a continuous compressed framework over the bearing surfaces
Floors made from cellular pre-stressed concrete slabs with a continuous compressed framework over the bearing surfaces
Floors ribbed with prefabricated girders and poured concrete or other prefabricated concrete components poured on site, with continuous bearing surfaces
Floors made with concrete poured on site over wide supporting metal profile strips, with continuous bearing surfaces
Traditional screeds or slabs using hydraulic cement binders
Liquid, cement-based screeds

#### Heated floors:

These instructions do not apply to installations on radiating or traditional night-storage heated floors.

#### 1.2 REQUIREMENTS FOR NEW SURFACES

##### • Flatness

There must be no high spots greater than 7mm under a 2 metre straight edge or higher than 2mm under a 200mm straight edge placed in any direction on the floor surface. Likewise, the flatness must be in accordance with the finishing requirements set by the Client.

##### • Levels

+/-10mm with respect to the reference level.

##### • Surface condition

In accordance with the provisions of the French Standard NF P14-201 (DTU 13.3) and professional tiling regulations.

##### • Cleanliness

Where the flatness has been corrected (>7mm) using a smoothing or levelling compound, the floor surface must be clean and solid, not friable or powdery, and free of cement rime (laitance) and loose particles (lint). The surface must be free of any residues that might affect its adherence

properties, such as oils, grease, acids, plaster, rendering, etc, and various stains, such as paint, plaster, tar, rust, fuels, etc.

When laying floors directly, use an industrial vacuum cleaner first.

##### • Dryness

The surface must be more than 28 days old (minimum period, often exceeded due to climatic drying conditions).

The residual water content must be measured by weight (using a calcium carbide tester) against the dry weight calculated from a sampling depth of 40mm.

Surface moisture testing should be used for statistical purposes only in order to identify the dampest areas then requiring accurate measurement.

##### • Localised re-profiling (localised levelling)

Use a repair mortar levelling compound or a resin-based filler.

## 2 SURFACE PREPARATION

### 1.3 PREPARATION OF NEW FLOOR SURFACES

#### a/ Physical preparation

Floor surfaces must be thoroughly prepared to remove any traces of dirt, laitence, curing products or any other foreign bodies.

The physical procedures must be based on the condition of the surface, the area to be prepared and their location. They include shot-blasting, sanding, grinding, scraping or diamond grit-blasting.

The surface must always be prepared properly.

#### b/ Preparing the joints

##### • Structural expansion joints set into the slabs

There must be no unevenness between two slabs.

Use inset expansion joints, e.g., COUVRANEUF Mifasol HO 38/42 from [www.cs-france.fr](http://www.cs-france.fr)

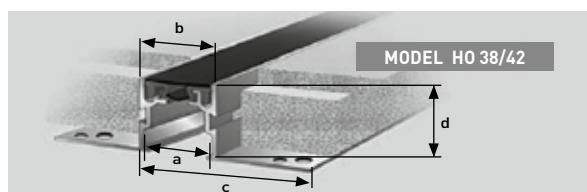

TYPE	a	b	c	d	Movement
	mm	mm	mm	mm	± mm
HD 38/42	33	38	128	42	5

##### • Expansion joints installed after laying GTI/GTI Max tiles

Since the GTI and GTI max tiles are of the loose-lay type, it is not necessary to align them either side of an expansion joint. If this should prove necessary, however, we recommend the use of an expansion joint cover strip.

These profile strips sit proud of the floor covering and are fixed either side.

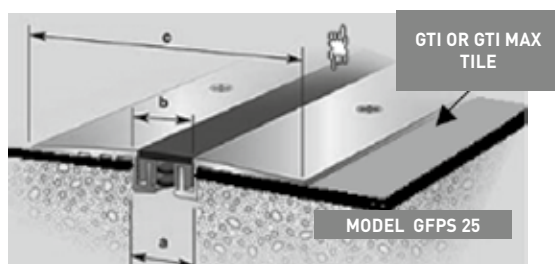

TYPE	a	b	c	d	Movement
	mm	mm	mm	mm	± mm
GFPS 25	25	30	110	5	5

##### • Construction joints

Where these result in a gap of <1mm and there is no unevenness, there is no need for preparation.

If the gap is greater than 1mm, they are to be prepared in the same manner as cracks.

##### • Shrinkage (contraction )joints

Where these result in a gap of <4mm, there is no need for preparation.

If the gap is greater than 4mm, they are to be prepared.

##### • Cracks

Gaps between 0.3mm and 1mm: no preparation.

Gaps of 1-4mm without unevenness: no preparation

Gaps of 1-4mm with unevenness: repair needed by the structural contractors (grind down step, vacuum clean thoroughly).

Gap >4mm: inspection, analysis and repair to be done by the structural contractors.

##### c/ Localised smoothing work

##### • For individual flatness faults

Required where the flatness is inadequate (>7mm under a 2m straight edge). The floor covering can only be laid where the surface provided for the floor covering contractor has the flatness required.

##### • For general flatness faults

Where the floor surface is unacceptable, it must be redone by the structural contractors. Smoothing may be necessary, especially where the floor surface does not have the required flatness or surface condition.

##### • Properties required by a surface free of (rising damp) (excess moisture) problems

- Removing high spots by grinding down and thorough vacuum cleaning

- Removing low spots:

- Flatness <7mm: up to standard
- Flatness >7mm: Apply a smoothing or levelling compound (structural contractor's job).

##### • Properties required by a surface with (rising damp) (excess moisture) problems

- Removing high spots by grinding down and thorough vacuum cleaning

- Removing low spots:

- Flatness <7mm: up to standard
- Flatness >7mm: Apply a SIKA type resin mortar (Sikatop 121 Surfage, Lank 730 Lankrep fin, Mapei Mapegrout). See NF standards for concrete repair products to be applied by the structural contractors. They are to be applied in accordance with the manufacturer's instructions and the following requirements:
  - Minimum surface cohesion: 1MPa
  - Sharply cut edges (using a disc cutter)
  - Dampened floor surface
  - Surface condition: light mortar skim

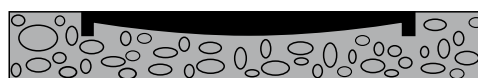

Cross section of resin mortar

## 2 SURFACE PREPARATION

### 2. Renovated floor surfaces and preparation of hydraulic concrete surfaces

#### ■ 2.1 BARE OR PAINTED CONCRETE

Prepare as for new floor surfaces

#### ■ 2.2 EXISTING FLOOR COVERING

The criteria for the removal or preservation of an existing floor covering are:

- If the defective area (damaged floor covering, etc.) is < 10% of the total area, keep the old covering
- Beyond 10%, the old covering must be removed completely.

#### a/ Tiles

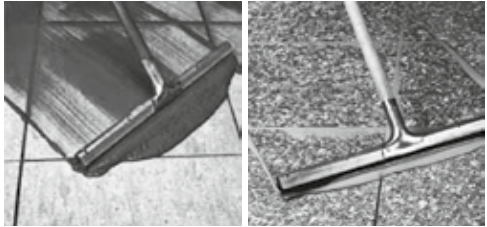
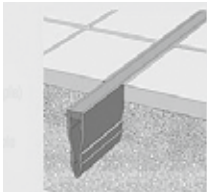
<b>TILES 10X10CM, 15X15CM, 20X20CM, 30X30CM</b>	<b>NB: The larger the tiles, the greater the risk of unevenness between tiles and hollow joints</b>	
<b>FLATNESS</b>	7mm under 2 metres	
<b>UNEVENNESS &gt;1MM, JOINTS &gt;4MM WIDE AND/ OR 1MM DEEP</b>	<p>A light, quick-drying, thixotropic smoothing compound to fill the dips may eradicate the problem, or a grouting compound, e.g., Mapei Ultracolor or Keracolor. Use a squeegee. Avoid build up by sweeping diagonally to the lay of the tiles. Sand down with a fine grit and vacuum clean the dust in order to leave the compound ONLY in the uneven areas.</p>	
<b>DEFECTIVE TILES</b>	<p>Those few tiles with defects may be removed, together with any areas not adhering to, or not firmly bonded to, the surrounding floor covering. Filling in should be done with a water-resistant resin mortar.</p>	
<b>SEPARATING JOINTS</b>	<p>The tiles either side of the joint should be examined and tapped lightly. If they are defective (starring, hollow-sounding, etc) they should be removed and replaced, together with any surrounding loose floor covering.</p>	<p>2-part flexible/rigid PVC profile strip. Standard colour: grey (other colours on request). Fire risk category M2 (low flammability). Good resistance to oils, dilute acids &amp; detergents.</p>  <p><b>USE</b> Resilient separation of glued floor coverings.</p> <p><b>DESCRIPTION</b> Rigid profile strip in different heights (8, 10, 12, 14, 16mm), with a central, soft rib.</p> <p><b>JF 8, JF 10, JF 12, JF 14, JF 16</b></p>
	<p>2-part flexible/rigid PVC profile strip. Standard colours: light grey, white, cream, old wood, clear (rib only). Other colours on request. Fire risk category M2 (low flammability). Good resistance to oils, dilute acids &amp; detergents. Supplied as 30x3 metre strips</p>  <p><b>USE</b> Resilient separation of sealed floor coverings and their mouldings.</p> <p><b>DESCRIPTION</b> - <b>JF 30</b> (filled) Rigid profile strip 30mm high (overall) with a central, soft rib. - <b>JO 30</b> (open) Rigid profiles strip as JF30 but without the flexible part. JF30s click into JO30s to give 45, 60, 75mm, etc, profile strips.</p>  <p><b>JF 30, JO 30</b></p>	

## 2 SURFACE PREPARATION

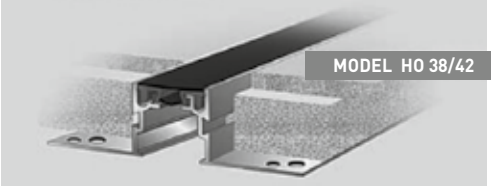
<b>STRUCTURAL EXPANSION JOINT</b>	It must remain connected to the slab. When replacing, use an inset expansion joint, e.g., COUVRANEUF Mifasol HO 38/42, or similar	
<b>FILLING</b>	The floor is then refurbished in layers, either with a levelling compound (with a suitable primer) or with a concrete repair mortar (see NF EN 1504-3).	
<b>SURFACE PREPARATION</b>	The tiles are to be washed with a soda cleaner, rinsed with water and dried.	

### b/ Poured resin floors (epoxy resin only)

Undamaged resin floors should be kept and repaired if it is planned to lay a new floor covering as a separate installation.

#### Spot repairs:

The resin can be removed by grinding or sanding followed by vacuum cleaning. It should be patched with an equivalent epoxy type resin.

<b>SURFACE</b>	Floors of poured epoxy resin.
<b>ADHERENCE</b>	No lifting of the resin and defects <10% of the surface area.
<b>FLATNESS</b>	7mm under 2 metres
<b>SPOT REPAIRS</b>	Prepare any cracks with gaps >4mm Prepare any holes or flaking with a diameter >10mm using an equivalent resin to the original.
<b>STRUCTURAL EXPANSION JOINTS</b>	These must remain connected to the slab. When replacing, use an inset expansion joint, e.g., COUVRANEUF Mifasol HO 38/42, or similar
<b>SURFACE PREPARATION</b>	A resin floor may be dry-sanded with a black abrasive disc, a tungsten carbide cutter or a diamond disc. The dust is then removed with an industrial vacuum cleaner.

### c/ Plastic semi-flexible tiles

Use interior flooring compounds for laying floor coverings. For repairs, floor coverings with underlays must always be removed.

- **Removing damaged tiles**

Those few tiles showing signs of damage can be removed with a hand scraper, together with any surrounding parts no longer glued down.

- **Filling**

The floor is then refurbished in layers, either with a smoothing or levelling compound (with a suitable primer) or with a SIKA type resin mortar (Sikatop 121 Surfacing, Lank 730 Lankrep fin, Mapei Mapegrout).

- **Surface preparation**

The remaining floor covering should be wet-sanded using a black sanding disc. The dust is then removed with an industrial vacuum cleaner.

## 2 SURFACE PREPARATION

<b>SURFACE</b>	Plastic semi-flexible tiles
<b>ADHERENCE</b>	>10%, complete repair. < 10% of the total area, check for adherence. Replace or re-glue non-adherent tiles
<b>FLATNESS</b>	7mm under 2 metres
<b>REMOVING DEFECTIVE TILES</b>	Defective tiles are to be removed together with any non-adherent parts or those not attached to the material below. See regulations above.
<b>STRUCTURAL EXPANSION JOINTS</b>	These must remain connected to the slab. When replacing, use an inset expansion joint, e.g., COUVRANEUF Mifasol HO 38/42, or similar
<b>FILLING</b>	The floor is then refurbished in layers, either with a levelling compound (with a suitable primer) or with a concrete repair mortar (see NF EN 1504-3).
<b>SURFACE PREPARATION</b>	The tiles are to be washed with a soda cleaner, rinsed with water and dried

### d/ Asbestos vinyl tiles

Laying any floor covering on such a surface calls for strict observance of current regulations.

Unglued but undamaged tiles are to be lifted and the missing or removed parts are to be filled in with a levelling compound and a suitable primer.

The remaining floor covering is to be washed with an alkaline detergent and then rinsed thoroughly.

<b>SURFACE</b>	Asbestos vinyl tiles.
<b>ADHERENCE</b>	>10%, complete repair. < 10% of the total area, check for adherence. Replace or re-glue non-adherent tiles.
<b>FLATNESS</b>	7mm under 2 metres.
<b>REMOVING DEFECTIVE TILES</b>	Defective tiles are to be removed together with any non-adherent parts or those not attached to the material below. See regulations above.
<b>STRUCTURAL EXPANSION JOINTS</b>	These must remain connected to the slab. When replacing, use an inset expansion joint, e.g., COUVRANEUF Mifasol HO 38/42, or similar.
<b>FILLING</b>	The floor is then refurbished in layers, either with a levelling compound (with a suitable primer) or with a concrete repair mortar (see NF EN 1504-3).
<b>SURFACE PREPARATION</b>	The tiles are to be washed with a soda cleaner, rinsed with water and dried.

### e/ Other surfaces

Carpets, LVT parquets, foam floor coverings (cushioned or foam-backed vinyls), stratified coverings, linoleum and resins other than epoxy must be removed completely and the floor surface specially prepared to match its condition and the preparation recommendations provided by the supplier of the surface preparation products.

## 3 INSTALLATION

### 1. Storage and site requirements

Before installing the covering, it should be inspected for any visual defect. If a visual defect is detected, please inform GERFLOR and do not begin installation without its agreement.



Ambient temperature  
10° C minimum



Laid on long double-sided  
adhesive strips  
every 500 m<sup>2</sup>

Since these shops are climate-controlled, the floor covering is not subject to temperature differences of more than 20° C.

Tiles should be stored on site 24-48 hours beforehand, at ambient temperature.

⚠ DO NOT MIX THE BATCHES

### 2. Laying method

Attraction® / GTI/ GTI Max tiles may be glued down as per DTU 53.2 but they are primarily designed for loose-lay installation (without glue) in sections of 500m<sup>2</sup>. For larger areas, divide the space into 500m<sup>2</sup> sections and glue down the tiles in the connecting areas.

### 3. Detailed installation information

#### ■ 3.1 POSITIONING EXTRA-WIDE DOUBLE-SIDED ADHESIVE STRIPS

##### Divide the area into 500m<sup>2</sup> sections

Since loose-lay installation is limited to 500m<sup>2</sup>, it is necessary to design the layout in 500m<sup>2</sup> sections, using pre-laid extra-wide double-faced adhesive strips.

Regardless of the configuration, SIGAN or D-TACK DUO-LAY double-sided adhesive strips should be applied never exceeding more than 20 rows of tiles.

Design the layout pattern so as to avoid laying double-side adhesive, or locating welds, in between sections in the areas between major aisles (in order to avoid excessive loadings).

##### • Typical layout for <500m<sup>2</sup> (clothing racks, cosmetics shelves, etc)

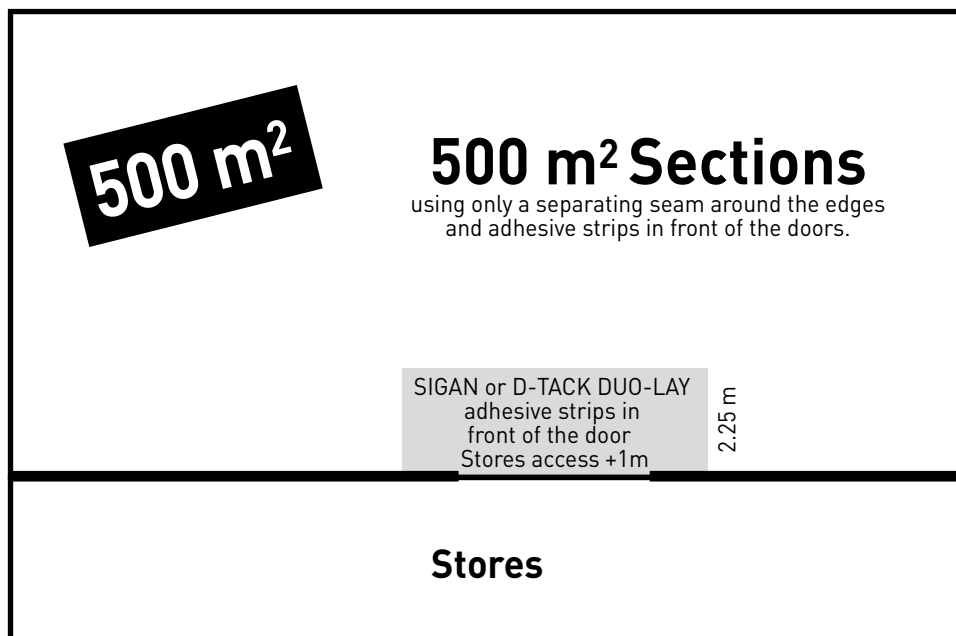



## 3 INSTALLATION

• Typical layout for a 2000m<sup>2</sup> food hall

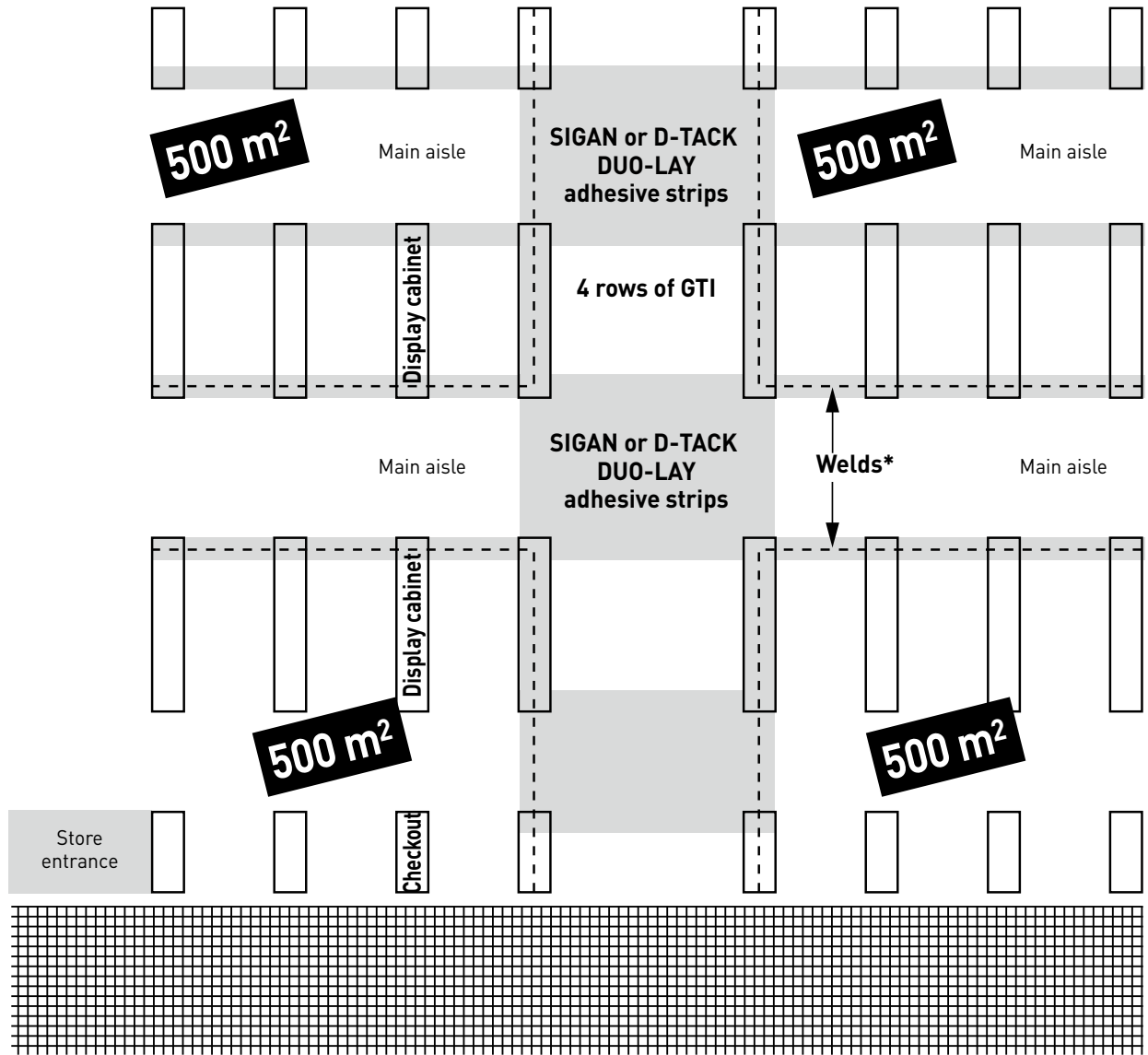

In each 500m<sup>2</sup> section there may be turning areas, liquid storage areas or stores entrances that will also need to be reinforced with double-sided adhesive.  
 Avoid placing 500m<sup>2</sup> section boundaries in a main aisle.

\* Where necessary [see paragraph 2.3.4]

## 3 INSTALLATION

### 3.2 LAYING DOUBLE-SIDED ADHESIVE STRIPS

SURFACE	PRIMER	TYPE OF ADHESIVE
Hydraulic cement Dryness ≤ 4.5% moisture (CCM)	PLANUS only under the adhesive	Sigan 1 from Sifloor
	Primer for hydraulic subfloor	Fix&Free from Gerflor
Hydraulic cement Dryness: Moisture content between 4.5 and 7% (CCM)	EPOXY PE 480 UZIN over the whole area	Sigan 1 from Sifloor
	Primer which can accept up to 7% CCM apply only under double side tape adhésif	Fix&Free from Gerflor
	No	2 part glue
Tiles	No	Sigan 2 or 3 from Sifloor
		DUO-LAY D-TACK
		Fix&Free from Gerflor
Resin, old PVC covering	No	Sigan 2 from Sifloor
		DUO-LAY D-TACK
		Fix&Free from Gerflor

Sigan 75 x 25 = 20 m<sup>2</sup> / D-TACK 100 x 25 = 25 m<sup>2</sup>

#### • Floor surface reminder:

The floor surface must be dry, hard, dust free, load-bearing, flat and free of all grease, dust and silicone.

**Shop windows.** Apply Uzin's extra-wide, double sided SIGAN or D-TACK DUO-LAY adhesive strips (type dependent on surface) in front of large windows (see Table 3.2).

#### • When using primer:

- Apply evenly to the surface at a coverage of 70 to 100 (max) g/m<sup>2</sup> using a foam roller in two directions at right angles.
- Avoid forming puddles, drops or streaks.
- Allow to dry for 2 hours (at least) in a well-ventilated space. Primer must be perfectly dry. The drying time depends on the floor surface, the weather and the ventilation. Tiles must not be laid directly on the primer.



- Testing adhesion: Roll down the double-sided adhesive strip thoroughly onto the surface. If the double-sided adhesive strip does not stick properly, apply another coat of primer.

#### • Laying double-sided adhesive strips:



- Roll out the double-sided adhesive strip, whilst pressing down lightly with a cork pressing block

**CAUTION:** The more adhesive (protected) side must never be laid on the floor surface.

- Only roll out the amount of Sigam strip that can be covered in one day with the floor covering.
- Roll up the remaining the double-sided adhesive strip, with its protective tape, to protect the surface and the tape from dust.

#### • Laying the PVC tiles on the adhesive

- Draw guidelines on the protective paper using a chalk line or a pencil.
- Mark the start point for the first tiles and the first row of tiles.
- Place a steel rule along the line and cut the protective paper only with a straight blade.
- Remove the protective paper from the adhesive strip by pulling it in a straight line and keeping it flat. This straight line then forms the start point for the first tiles of the first row.
- Lay the tiles, locking their edges together.
- Stack the protective paper as required and then roll it up (to minimise the volume of waste).
- Pull back the protective paper as required, keeping it straight and flat.
- If there is a delay in the laying process, the protective paper can be put back in place to protect the strips.
- After installation, press down or roll down in two directions, at right angles, all across the floor.

#### • Removing the tiles and double-sided adhesive strips:

**Double-sided adhesive strips allow you to remove the floor covering without leaving glue traces and without damaging the floor surface.**



- Separate the tiles
- Starting from one corner, separate the double-sided adhesive strip from the floor surface.
- Pull back the floor covering with the double-sided adhesive strip by pulling it flush with the ground.

## 3 INSTALLATION

### 3.3 LAYING ATTRACTION® / GTI / GTI MAX TILES

#### • Precautions

#### 1- Tiles are delivered on palettes.

Never mix tiles from different batches.

- 2- Direction: The tiles must ALL be laid in the same direction. This direction is indicated by an arrow on the back of each tile.

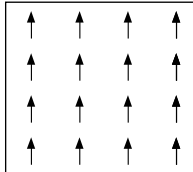

- 3- The pressed materials used with GTI and GTI Max and ATTRACTION® tiles may have colour differences or dimensional variations between series of up to 1mm. In such cases:

#### - Either, the tiles may not interlock easily

In this case, cut off the dovetails and weld the tiles after first putting down a double-sided adhesive strip on either side of the weld.

#### - or, they may interlock loosely

In this case, apply a double-sided adhesive strip under both tiles to ensure that they do not come apart over time.

#### 3.3.1. Laying out the guidelines

##### - General case

Start in a cross pattern from the middle of the room  
Lay the tiles in staircase pattern ¼ by ¼ of the room

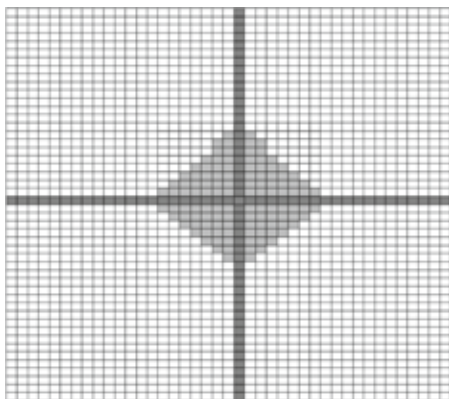

#### 3.3.2 Laying along a wall

Start in the middle of the layout  
Lay the tiles in staircase pattern on either side

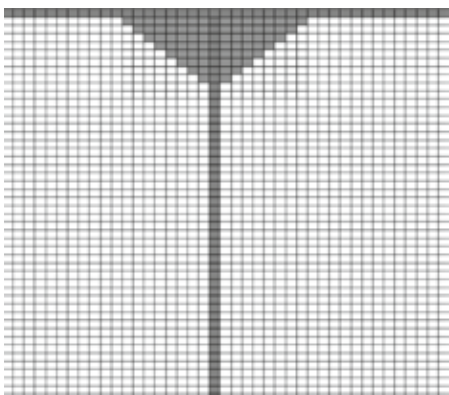

#### 3.3.3. Laying around gondolas (fruits and vegetable)

ETAPE 1: Border the gondolas/shelves with a row of GTI tiles

ETAPE 2: Connect the gondolas/shelves with each other

ETAPE 3: Finish by filling in

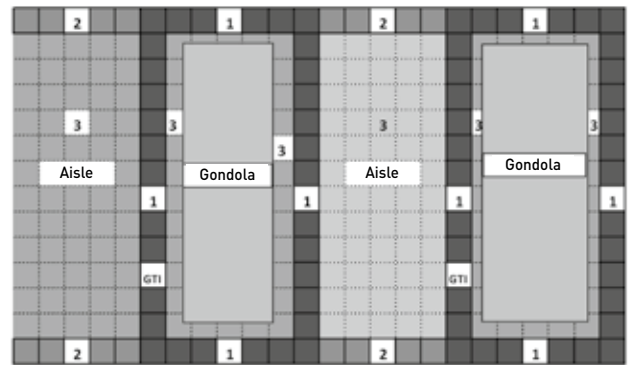

- 1 Border the gondolas/shelves with a row of GTI tiles
- 2 Connect the gondolas/shelves with each other
- 3 Place the GTI tiles in the aisles and under the gondolas

#### 3.3.4. Laying out in refrigerated areas (freedger and freezer)

- Apply double-sided tape over the entire surface before laying tiles GTI / GTI MAX to limit the ingress of water in case of leakage or failure.

#### 3.3.5. Mark out the guidelines for a 500m<sup>2</sup> section

- Lay ladder-style for easier interlocking of tiles and to keep them in true. Tiles are to be laid ladder-style and **ALL** in the same direction (use the arrows on the back of the tiles).

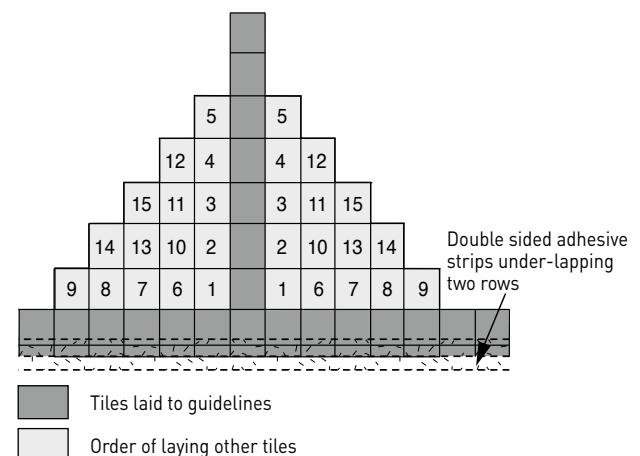

#### 3.3.6. Interlocking the tiles (method, tools, etc) and making adjustments

- Tiles are to be interlocked using a synthetic or rubber mallet and a wooden block.
- Interlocking is to be done from a corner to the edge.



## 3 INSTALLATION

Tools required: Knife, metre rule, steel straight edge, metal roller, wooden or synthetic resin mallet.

	GERFLOR	JANSER	ROMUS	WOLFF
Synthetic mallet	0 530 0001	N/K	94964	N/K

### 3.3.7. Edge trimming

The tiles are to be laid out such that any cut edges are more than 1/2 tile wide

### 3.3.8. Cutting out (method, tools, etc)

- Edge clearance: as standard, the edge clearance is to be 5mm
- Keep a circular saw bench available for use throughout the job
- Cuts are to be made with a trimming knife (1 cut on the top surface and one on the back) or by overlap cutting (gauging)  
Overlap cutting: A procedure for marking or cutting out parallel lines. One can use a gauge or a tile.
- Take a complete tile to use as a gauge piece
- Place the gauge piece over the tile to be cut, holding it against the wall. Leave 5mm clearance.
- Mark the tile to be cut all along the edge of the gauge piece using a knife with a straight blade.

- Cut off the part of the tile to be laid neatly and then fit it into place.

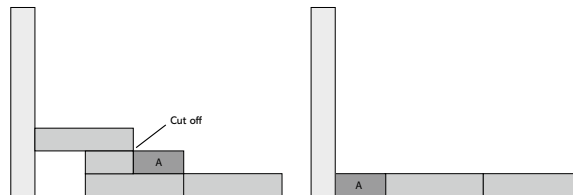

- For awkward areas (doorframes, etc) use calliper moulding shears.



**Moulting shears with mitre guide**  
Gerflor : 0566 0001  
Janser : 237 530 000  
To cut around the feet of doorframes and in awkward places.  
Available from Gerflor



**Calliper moulding shears with mitre guide**  
Janser : 262 284 000  
To cut around the feet of doorframes and in awkward places.

### 3.4 HOT WELDING

SEAM BETWEEN PRODUCTS		ROD PART NO.	ACCESSORIES
GTI	GTI Max	CR 50 / CR 40	
GTI / GTI Max	ATTRACTION®	CR 50 / CR 40	1mm tapering profile strip
GTI / GTI Max	Creation Clic 70*	CR 50 / CR 40	

\* see Creation Clic 70\_chapter 4 Finishing and junctions

#### Weld using a Gerflor CR50/CR40 rod



Place the 1mm tapering strip under the Attraction® tile

#### Weld using a Gerflor CR50/CR40 rod



Lay directly over double-sided strip and then weld

## 3 INSTALLATION

### • Method

Hot welding calls for three stages of work after laying the floor covering.

#### 1- Chamfering

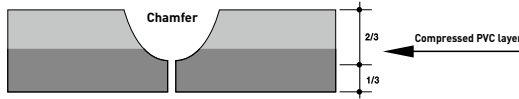

Tools required:

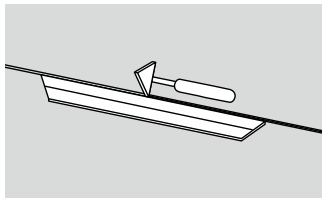

Tools: triangular scraper and straight edge

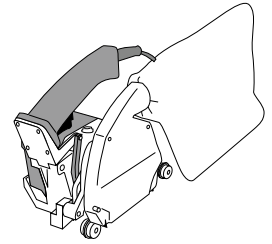
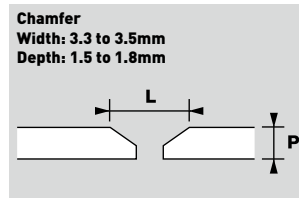
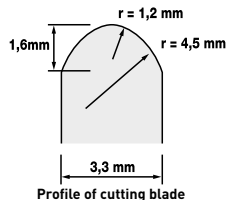

Chamfer machine

#### 2- Hot welding

WITH A HIGH-SPEED NOZZLE

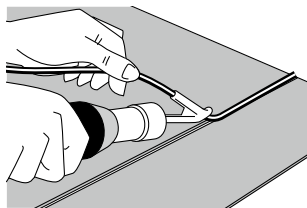

Nozzle part no. GERFLOR : 0563 0001



BY MACHINE

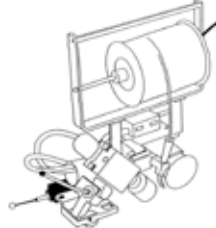

Use a LEISTER UNIVERSAL or UNIFLOOR welding machine with an electronically variable hot air heat source and a multi-jet nozzle with the small jet designed 2mm for this purpose.

#### 3- Trimming the weld seam flush

##### • Using a MOZART cutter

**1st pass:** Rough trim by placing the trimmer guide under the MOZART cutter blade (fig 1)

**2nd pass:** (The weld seam must be totally cold)

Turn the trimmer guide through 90° to one side to remove any excess weld rod seam completely (fig 2).

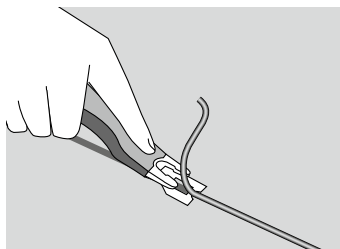

Fig 1. Trimmer guide under blade

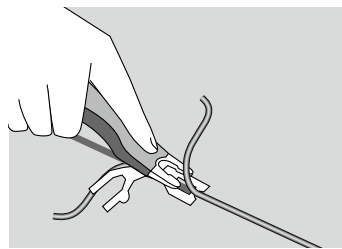

Fig 2. Trimmer guide at 90°

This trimming method avoids leaving hollow weld seams.

TOOLS	GERFLOR PART NO.
MOZART cutter	0561 0001
Spare blades	0542 0001

## 4 FINISHING AND JUNCTIONS

### 1. Around pillars

The 5mm edge clearance should be filled with a MS polymer mastic.

This filling may be covered over by a rigid or flexible baseboard.

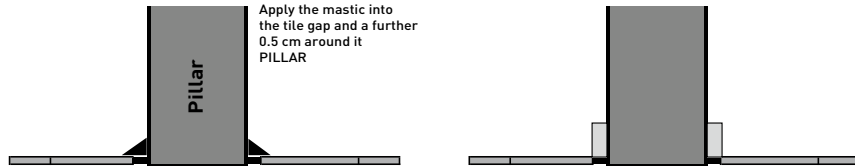

### 2. Along wall edges with an existing baseboard

The 5mm edge clearance should be filled with a MS polymer mastic.

This filling may be covered over by a glue-on rigid or flexible baseboard.

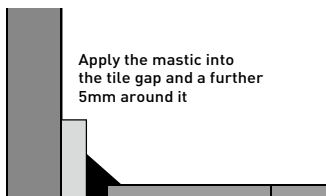

### 3. Along wall edges

The 5mm clearance should be filled with a MS polymer mastic.

This filling may be covered over by a rigid or flexible baseboard.

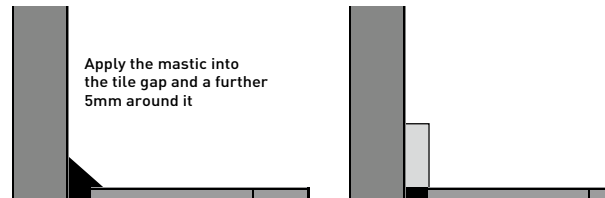

### 4. Around pipe-work and door frames

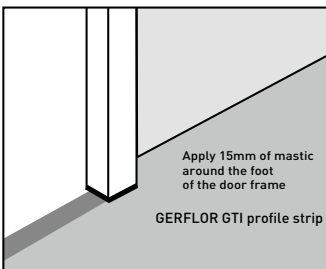

Apply a PU or MS polymer mastic to the cut out clearance.

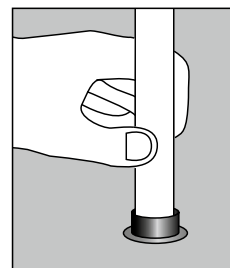

Fill around with MS polymer mastic.

### 5. Joining two 500m<sup>2</sup> sections or changing colours

**Two options:**

#### 1. No problems interlocking tiles across two 500m<sup>2</sup> sections:

Lay out and interlock the tiles using pre-laid extra-wide, double-sided adhesive strips.

#### 2. Non-alignment of tiles across two 500m<sup>2</sup> sections

- Cut off the dovetails, ensuring that the tiles are absolutely square for their full length
- Mark a line 550 mm from the cut with a chalk line
- Lay two longitudinal rows
- Use these two rows to position the tiles to be cut
- Cut the tiles using the gauge piece method but leave 1mm for a hot weld seam
- Continue to lay the tiles ladder-style

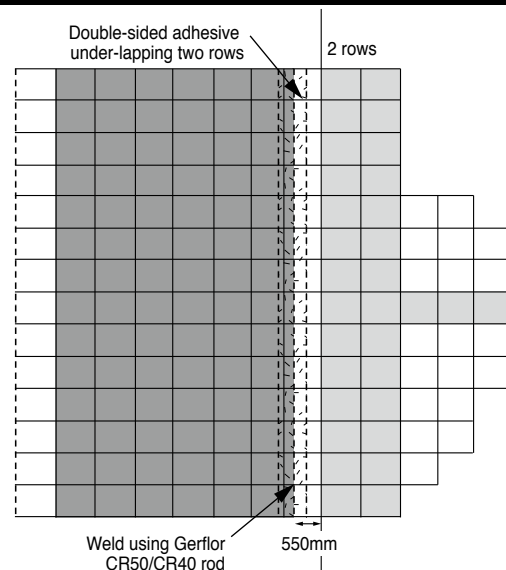

## 4 FINISHING AND JUNCTIONS

### 6. Intersections between GTI/GTI Max, GTI/ATTRACTION® or GTI Max/ATTRACTION® tiles

- Cut off the dovetails, ensuring that the tiles are absolutely square for their full length
- Mark a line 550 mm from the cut with a chalk line
- Lay two longitudinal rows of the second tile type
- Use these two rows to position the tiles to be cut
- Cut the tiles using the overlap method but leave 1mm for a hot weld seam
- Continue to lay the tiles ladder-style

**NB.** For joints with Attraction® tiles, glue a 1mm tapering edge strip to the GTI or GTI Max side

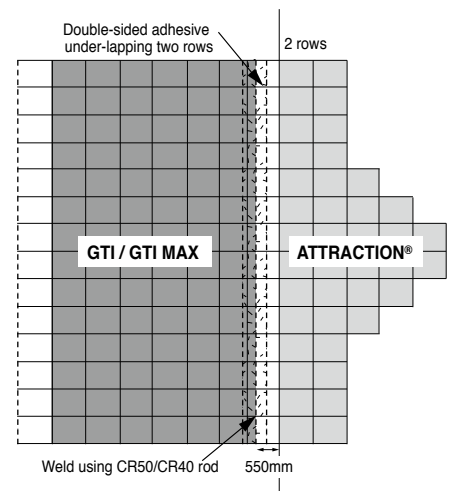

### 7. GTI/GTI Max junction with Creation Clic 70

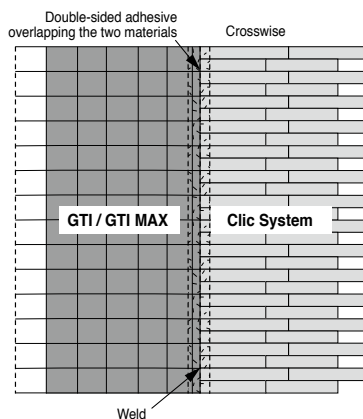

#### 7.1. GTI/GTI MAX/ATTRACTION®/CREATION CLIC 70 CROSSWISE JUNCTION

**GTI / GTI Max / Attraction®:** Cut off the dovetails, and / or leave a maximum gap of 1 mm. Place a double-sided adhesive under the tiles.

**Creation Clic 70:** Cut the boards leaving a maximum gap of 1 mm. Place a double-sided ultra-wide adhesive (SIGAN) overlapping the two materials. Chamfer, weld and trim as per the installation instructions.

#### 7.2 GTI/GTI MAX/ATTRACTION®/CREATION CLIC 70 LENGTHWISE JUNCTION

**GTI / GTI Max / Attraction®:**

Cut off the dovetails, and / or leave a maximum gap of 1 mm. Place a double-sided adhesive under the tiles.

**Creation Clic 70:**

Cut the boards to eliminate the vertical click-fit.

Place a double-sided ultra-wide adhesive (SIGAN) overlapping the two materials.

Chamfer, weld and trim as per the installation instructions.

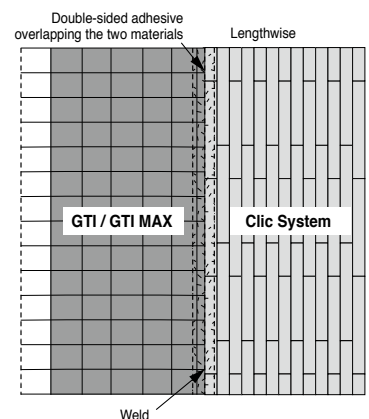



## 4 FINISHING AND JUNCTIONS

### 8. Junction between tiles or store doorways with Attraction/GTI/GTI MAX

- Install the GTI/Attraction 0505 edge profile, checking that it is attached 5 cm from the edges.
- Stainless steel screws and plugs are supplied with the profiles.

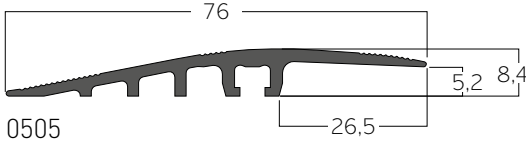

**0505**  
**3 metre long profile strip with 9 pre-drilled countersunk holes, 4.3mm diameter.**

- The spacing between holes is 313 mm
- The first hole is 90 mm from the end
- The holes are de-burred after drilling

#### 4x50mm TFZ screws and 6x30mm

TFZ 4mm diameter screw, 50mm long

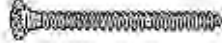

6mm diameter plug, 30mm long

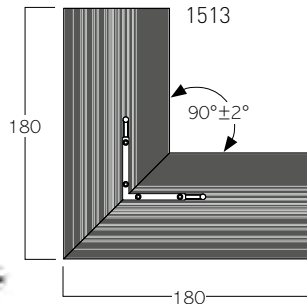

#### 1513 Inside corner profile

Packaging: 4  
 Supplied with 8 screws,  
 8 plugs and 4 connectors  
 Dimensions: 180 x 180 mm

### 9. Joints around fixed or un-dismounted cabinets with GTI/GTI Max

Areas around a gondola shelving unit on a concrete or original material covered floor surface

- Cut the tiles to a distance of between 100 and 150mm from the cabinet.
- Install a GTI H202 edging strip, checking that it is attached 50mm from the edges. Use 4x40 or 50mm countersunk, flat and crosshead stainless steel screws and the appropriate plugs for the floor surface.
- It is a good idea to place low guard rails in front of the cabinets.

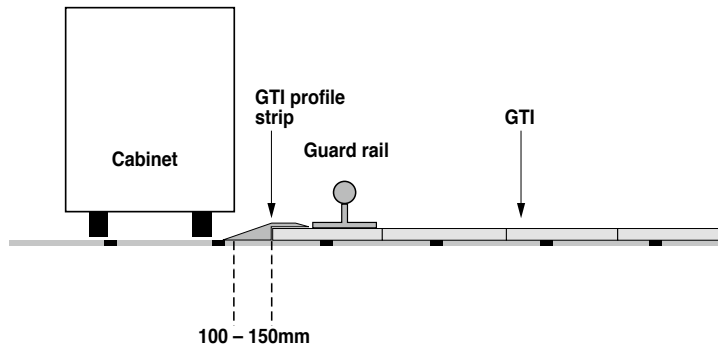

## 5 LAYING TBS SELF-ADHESIVE STRIPS ON GTI IN FRONT OF FRUIT & VEGETABLES GONDOLAS

If it is liable to be slippery in front of the fruit and vegetables gondolas, we suggest that you apply an anti-slip self-adhesive strip

Length:	10 metres
Width	60cm
Colours	Black C 08
Roll diameter	17cm
Weight/m <sup>2</sup>	2,4kg
Thickness	1,6mm
Best before:	1 year

#### Laying:

- Lay the TBS strip only on GTI or GTI Max tiles
- Tiles must be clean and dry when the strip is laid
- Lay the strip keeping in line with the gondola covering at least one row of dovetail
- Pull off the protective film from the adhesive strip as you work
- Press down the strip with your hand, and then with a smoothing roller

#### Replacing TBS strips (recommended every 6 months)









When this strip needs to be replaced:

- Carefully cut 15 to 20 cm wide strips
- Carefully pull out this strip with your hand
- Keep in line with the strip to avoid starting a fracture
- Clean the GTI surface with a power scrubber and an alkaline detergent to remove any adhesive residue

## 6 FINAL CLEANING

**Commissioning may take place immediately after the installation of the floor covering, however the following points should be observed.**

- The floor covering must be cleaned once the installation work is finished, but no less than 24 hours afterwards
- Remove all dust and off-cuts with a broom and industrial vacuum cleaner
- Wash the floor with a power floor cleaner /scrubber and an alkaline detergent
- Rinse with clean water to eliminate all traces of detergent
- Allow to dry

EQUIPMENT TYPE	CHEMICAL	METHOD	FREQUENCY
<b>INITIAL OR DEEP CLEAN</b>			
 +  Auto-scrubber + Red disk    or  Scrubbing brush Squeegee or Wet vacuum cleaner	<b>Dynatech Trophy</b> 10% solution*	<ul style="list-style-type: none"> <li>• Clean with the auto-scrubber (vacuum suction switched off), and allow the product time to work</li> <li>• Work in strips, overlapping the lines</li> <li>• Vacuum</li> <li>• Finish along the display units with the scrubbing brush + squeegee or wet vacuum cleaner</li> </ul>	As necessary
	<b>Rochex ROCTONIC</b> 3% solution		
	<b>Kiehl DOPOMAT INTENSO</b> 2% solution		
	<b>ECOLAB NEOMAT A</b> 2% - 3% solution		
<b>ENTRETIEN COURANT</b>			
 +  Auto-scrubber + Red disk   Flat mop	<b>Dynatech Trophy</b> 1-2% solution*	<ul style="list-style-type: none"> <li>• Clean with the auto-scrubber</li> <li>• Work in strips, overlapping the lines</li> <li>• Vacuum</li> <li>• Finish along the display units using the flat microfibre mop</li> </ul> <p>⚠ String mops deposit too much residue (product/ water)</p>	Daily
	<b>Rochex ROCTONIC</b> 1% solution		
	<b>Kiehl DOPOMAT INTENSO</b> 0.3% solution		
	<b>ECOLAB MAGIC MAXX</b> 1% solution		

Note: Do not use too much water on the flooring, to avoid water seeping between the tiles

\*Distributed by Gerflor - Code: 085E 0001

### MANUFACTURERS' ADDRESSES

#### POWER FLOOR CLEANERS/SCRUBBERS

##### TENNANT

383 rue Belle Etoile  
95700 Roissy en France  
Tel. : +33 (0)1.49.90.50.00

##### NILFISK

26 av. de la Baltique BP 246  
91944 Courtaboeuf Cedex  
Tel. +33 (0)1 69 59 87 00

#### CLEANING MATERIALS

##### LABORATOIRE ROCHEX

3 avenue des Buchillons BP 263  
74106 Annemasse  
Tel. : +33 (0)4.50.37.49.54

##### KIEHL FRANCE

1 rue de l'industrie BP 54  
67172 Brumath  
Tel. : +33 (0)3.88.59.52.25

##### ECOLAB

8, rue Rouget de Lisle  
92442 Issy les Moulineaux  
Tel. : +33 (0)1.40.93.93.94

For further details, please contact our engineering support department.

## 7 REPLACING FURNITURE

- Consoles (whether stocked or not) and other display units must be put back in place by moving them on Fourmi movers (<http://www.fourmi-distribution.com/>) to prevent slippage of the material.
- **Neither the installers nor the manufacturers will accept any responsibility for damage caused to the floor covering by the replacement of furniture items.**

## 8 RÉPARATION ET MAINTENANCE

### ■ 8.1. ROUTINE INSPECTION, MAINTENANCE AND REPAIRS

Users must regularly inspect the visual appearance of the work and inform the Client and/or the original installers of any problems that may, in their opinion, lead to a premature failure of the work.

A special survey, where requested from the licensees by the users, should be able to identify the differences between ageing associated with normal wear and tear, traffic and use of the premises, and any damage of an accidental nature.

If the users' observations appear valid after the special survey, the installers will carry out the repair work under their contractual or statutory obligations.

#### COMMENT:

As part of this routine inspection, users should immediately notify any accidents arising from working in the premises and, in particular, any gashes due to dropping sharp instruments, burns, etc, so that repairs can be made.

Such maintenance may be carried out by the user's own maintenance department.

### ■ 8.2. REPLACING ATTRACTION® / GTI / GTI MAX TILES

#### • Replacing loose-laid tiles

- Cut out one corner of the damaged tile
- Unclip the dovetails
- Replace with a new tile, following the tiles' direction.

#### • Replacing glued-down tiles

- Cut out one corner of the damaged tile
- Unclip the dovetails
- Cut out and replace the adhesive strip
- Replace with a new tile, following the tiles' direction.



## 9

## ENTRANCE MAT INCORPORATING ROMAT GT FROM ROMUS

### EQUIPMENT NEEDED:

Knife with straight blade / Square / Rule / Tape Measure / CORDEX /  
EXAKT Saw circular type DC170 (ROMUS ref: 93891) Screwdriver Torx T10

### 1. Incorporating an Entrance Mat

The installation of the entrance mat is to be performed after completion of the Attraction® / GTI / GTI Max tiles.

Identify the area of the entrance mat by drawing a rectangle of 152.5 x 102.5 cm on the Attraction® / GTI / GTI Max tiles.

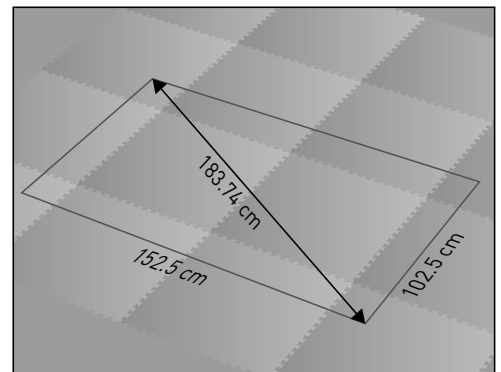

### 2. GTI Removal

Cut along the trace line on the surface of the Attraction® / GTI / GTI Max tile with an EXAKT DC170 saw (ROMUS ref: 93891) to a depth of 1mm less than the thickness of the Attraction® / GTI / GTI Max tile (eg 5mm versus 6mm for a GTI tile) and stopping at few centimeters from the corners.

Finish cutting the material at the corners with a straight blade knife.

Clear the area of material.

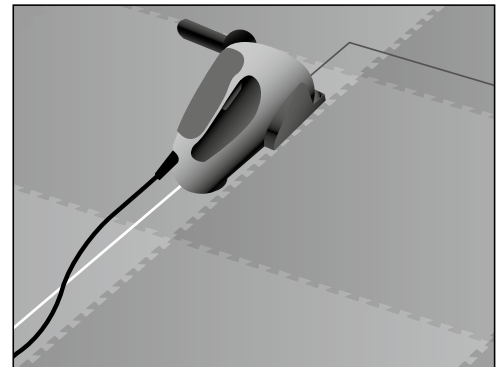

### 3. Setting the Entrance Mat Frame

#### 3.1. PLACING THE BASES

Position the 4 bases under the Attraction® / GTI / GTI Max leaving a clearance of 3-5 mm. Leave a 5cm gap at each corner.

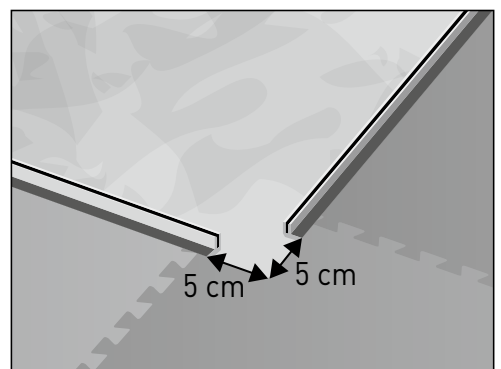
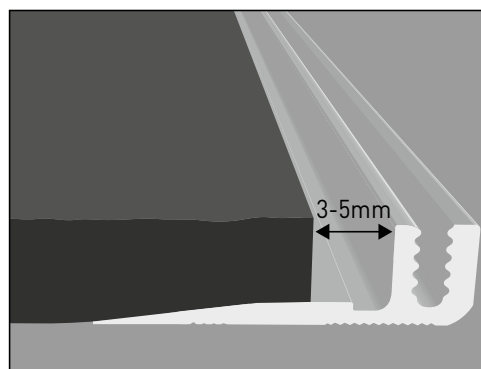

## 9 ENTRANCE MAT INCORPORATING ROMAT GT FROM ROMUS

### ■ 3.2. INSTALLATION OF THE CORNERS

Place the 4 corners loosely in position (Do not fix).

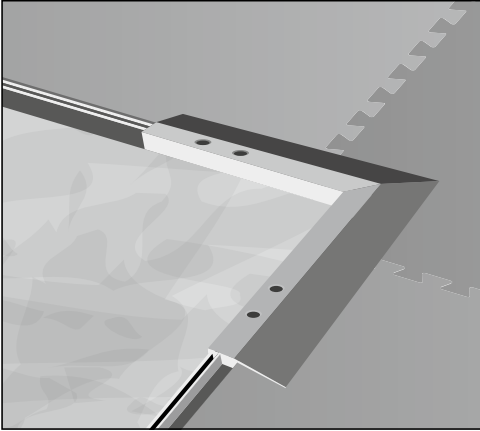

### ■ 3.3. INSTALLATION OF UPPER RAMPS

Position the 4 upper ramps.

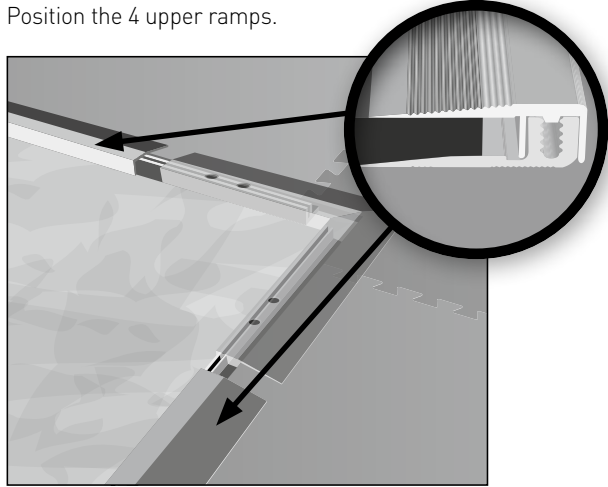

### ■ 3.4. TIGHTENING THE UPPER RAMPS

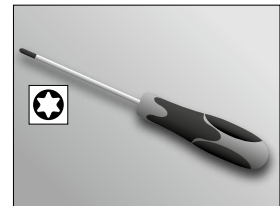
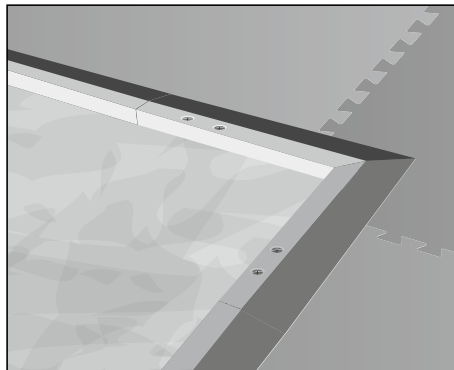
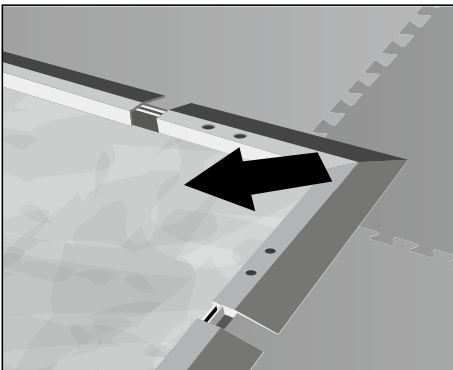

Ensure a tight fit between the 4 corners and the adjoining ramps.  
Screw ramps and corners using a Torx screwdriver (No. 10).

## 4. Setting up the entrance mat in the frame

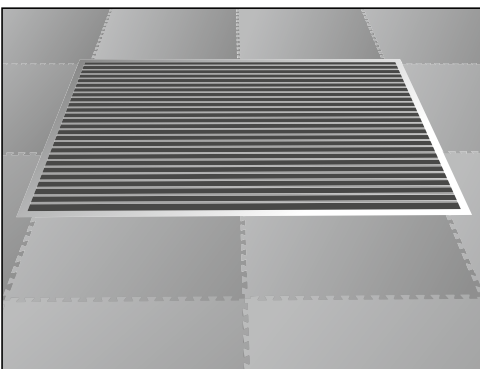

Unroll the pre-made mat into place, ensuring it is square to the area and flat to the floor.

GTI / GTI MAX CONTROL



GTI / GTI MAX  
CONTROL

---

# GTI / GTI MAX CONTROL

## 1 SCOPE OF USE

SALES AREA	TYPE OF PRODUCTS SOLD IN THESE AREAS	CONDITIONS
PRACTICAL	Small DIY, car, luggage	<ul style="list-style-type: none"> <li>- Pedestrian traffic</li> <li>- Trolleys</li> <li>- Manual forklift</li> <li>- Electric forklift operated by a driver capacity 1300kg</li> </ul>
CLEANING	Laundry, cleaning products, multi-use, deoderants, bins, haberdashery, brushes	
GROCERY	Sweets, biscuits, crisps, tinned goods, carbohydrates	
HOUSEHOLD	Kitchen, decoration, household linen, crockery, cooking, small and large electrical goods	
PETS	Food, health, accessories	
DRINKS	Fruit juices, water, beers, sodas	
WINE/ SPIRITS	Wine, spirits, champagne	
STORAGE	-	
SEASONAL EVENTS	Offers and promotions	
FRESH	Butter, cream, cheese, eggs, yoghurts, milk	

### INTRODUCTION – CONDITIONS FOR USE

	INDENTATION (P) RATING FOR NEW AND RENOVATED AREAS	TEMPERATURE CONSIDERATIONS	PERIPHERAL EXPANSION
GTI UNI* GTI DECOR	P3 areas that also have to bear heavy wheeled traffic within the limits shown below. Cleaning is limited to, at most, a powered floor cleaner.	Since these shops are climate-controlled, the floor covering is not subject to temperature differences of more than 20°C. The dimensional stability of GTI/GTI Max tiles allows loose laying up to 500m <sup>2</sup> .	Since the buildings are temperature controlled all year round, GERFLOR recommends an edge clearance of 5mm.
GTI MAX UNI** GTI MAX DECOR	P4 areas that also have to bear heavy mobile or static loads. Cleaning is limited to, at most, a powered floor cleaner.		

\* GTI UNI : 0245 Grey / 0241 Red / 0244 Yellow / 0242 Black / 0246 Dark Grey / 0240 Green / 0243 Blue

\*\* GTI MAX UNI : 0250 Tiger / 0251 Puma



## 1 SCOPE OF USE

### INTRODUCTION - CONDITIONS FOR USE

	RESISTANCE TO STATIC LOADS
	MAXIMUM PRESSURE
<b>ATTRACTION®</b> GTI UNI GTI PURE DECOR	< 40 kg / cm <sup>2</sup>
GTI MAX DECOR	< 50 kg / cm <sup>2</sup>

### GERFLOR GTI TILES ARE SUITABLE FOR THE TRAFFIC OF MANUAL AND ELECTRIC PALLET TRUCKS

#### Precautions for electric pallet trucks:

1. Choose models with speed controller
2. Preferably use polyurethane wheels
3. Ask the manufacturer's technicians to adjust 3 important settings depending on the loads transported:
  - Max speed
  - Acceleration speed
  - Deceleration speed

#### Recommended pallet truck models:

- BT TOYOTA : - Electric: BT Levio W range, LWE140, 160, 180, 200 models  
- Manual: BT Lifter range
- STILL : - Electric: EXU range, EXU 16, 18, 20, 22 models  
- Manual: HPT or HPS range
- FENWICK : - Electric: T16, T18, T20 models

<b>TYPE OF USE</b>	Electric pallet truck with controller
<b>TYPE OF WHEELS</b>	Polyurethane wheels (for example, Vulcolan)
<b>STANDARD SPEED 6 KM/H</b>	Recommended standard speed: 80% of max permitted = 4.8 km/h
<b>LOAD WEIGHT: UP TO 1,500 KG INCLUDED</b>	OK
<b>LOAD WEIGHT UP TO 2,000 KG</b>	Marking effect
<b>LOAD WEIGHT &gt; 2,000 KG</b>	Burn effect
<b>STATIC LOAD</b>	No limit
<b>DYNAMIC LOAD</b>	OK up to 2,000 kg of load on pallet truck

#### Heavy pallets (water) placed on shelves

Burn in case of acceleration of the pallet truck at stop position

\*heaviest load in supermarket = 1,200 kg (1 pallet of water)

## 2 SURFACE PREPARATION

This information is valid on 01.03.2012. Check that it remains compatible with any changes to your local building code.

The purpose of this manual is to remind all relevant parties of the inspection, acceptance and preparation procedures to be performed compulsorily before applying thin floor coverings on large food-compatible surfaces.

A reminder is given that the surface must compulsorily be inspected both by supplier and client (refer to Appendix A).

### 1. New floor surfaces and preparation of hydraulic concrete surfaces

#### ■ 1.1 TYPES OF NEW FLOOR SURFACE

SURFACE TYPE
Flooring on a direct to earth platform
Floor on a flat slab using poured concrete with continuous bearing surfaces
Floor on a flat slab using preformed concrete shuttering slabs and poured concrete with continuous bearing surfaces
Floors made from cellular reinforced concrete slabs with a continuous compressed framework over the bearing surfaces
Floors made from cellular pre-stressed concrete slabs with a continuous compressed framework over the bearing surfaces
Floors ribbed with prefabricated girders and poured concrete or other prefabricated concrete components poured on site, with continuous bearing surfaces
Floors made with concrete poured on site over wide supporting metal profile strips, with continuous bearing surfaces
Traditional screeds or slabs using hydraulic cement binders
Liquid, cement-based screeds

#### Heated floors:

These instructions do not apply to installations on radiating or traditional night-storage heated floors.

#### ■ 1.2 REQUIREMENTS FOR NEW SURFACES

##### • Flatness

There must be no high spots greater than 7mm under a 2 metre straight edge or higher than 2mm under a 200mm straight edge placed in any direction on the floor surface.

Likewise, the flatness must be in accordance with the finishing requirements set by the Client.

##### • Levels

+/-10mm with respect to the reference level.

##### • Surface condition

In accordance with the provisions of the French Standard NF P14-201 (DTU 13.3) and professional tiling regulations.

##### • Cleanliness

Where the flatness has been corrected (>7mm) using a smoothing or levelling compound, the floor surface must be clean and solid, not friable or powdery, and free of cement rime (laitance) and loose particles (lint). The surface must be free of any residues that might affect its adherence

properties, such as oils, grease, acids, plaster, rendering, etc, and various stains, such as paint, plaster, tar, rust, fuels, etc. When laying floors directly, use an industrial vacuum cleaner first.

##### • Dryness

The surface must be more than 28 days old (minimum period, often exceeded due to climatic drying conditions).

The residual water content must be measured by weight (using a calcium carbide tester) against the dry weight calculated from a sampling depth of 40mm.

Surface moisture testing should be used for statistical purposes only in order to identify the dampest areas then requiring accurate measurement.

##### • Localised re-profiling (localised levelling)

Use a repair mortar levelling compound or a resin-based filler.

## 2 SURFACE PREPARATION

### 1.3 PREPARATION OF NEW FLOOR SURFACES

#### a/ Physical preparation

Floor surfaces must be thoroughly prepared to remove any traces of dirt, laitence, curing products or any other foreign bodies.

The physical procedures must be based on the condition of the surface, the area to be prepared and their location.

They include shot-blasting, sanding, grinding, scraping or diamond grit-blasting.

The surface must always be prepared properly.

#### b/ Preparing the joints

##### • Structural expansion joints set into the slabs

There must be no unevenness between two slabs.

Use inset expansion joints, e.g., COUVRANEUF Mifasol HO 38/42 from [www.cs-france.fr](http://www.cs-france.fr)

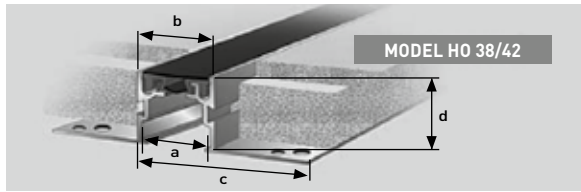

TYPE	a	b	c	d	Movement
					±
	mm	mm	mm	mm	mm
HD 38/42	33	38	128	42	5

##### • Expansion joints installed after laying GTI/GTI Max tiles

Since the GTI and GTI max tiles are of the loose-lay type, it is not necessary to align them either side of an expansion joint. If this should prove necessary, however, we recommend the use of an expansion joint cover strip.

These profile strips sit proud of the floor covering and are fixed either side.

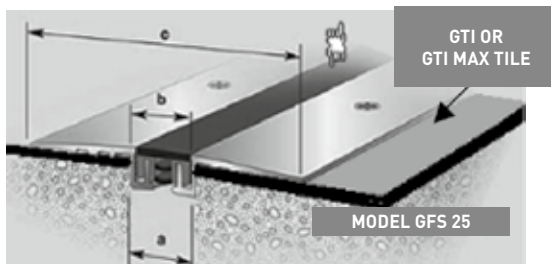

TYPE	a	b	c	d	Movement
					±
	mm	mm	mm	mm	mm
GFPS 25	25	30	110	5	5

##### • Construction joints

Where these result in a gap of <1mm and there is no unevenness, there is no need for preparation.

If the gap is greater than 1mm, they are to be prepared in the same manner as cracks.

##### • Shrinkage (contraction) joints

Where these result in a gap of <4mm, there is no need for preparation.

If the gap is greater than 4mm, they are to be prepared.

##### • Cracks

Gaps between 0.3mm and 1mm: no preparation.

Gaps of 1-4mm without unevenness: no preparation

Gaps of 1-4mm with unevenness: repair needed by the structural contractors (grind down step, vacuum clean thoroughly).

Gap >4mm: inspection, analysis and repair to be done by the structural contractors.

##### c/ Localised smoothing work

###### • For individual flatness faults

Required where the flatness is inadequate (>7mm under a 2m straight edge). The floor covering can only be laid where the surface provided for the floor covering contractor has the flatness required.

###### • For general flatness faults

Where the floor surface is unacceptable, it must be redone by the structural contractors. Smoothing may be necessary, especially where the floor surface does not have the required flatness or surface condition.

##### • Properties required by a surface free of (rising damp) (excess moisture) problems

- Removing high spots by grinding down and thorough vacuum cleaning

- Removing low spots:

• Flatness <7mm: up to standard

• Flatness >7mm: Apply a smoothing or levelling compound (structural contractor's job).

The performance of the compound must satisfy the P4S specifications.

##### • Properties required by a surface with (rising damp) (excess moisture) problems

- Removing high spots by grinding down and thorough vacuum cleaning

- Removing low spots:

• Flatness <7mm: up to standard

• Flatness >7mm: Apply a SIKA type resin mortar (Sikatop 121 Surfacing, Lank 730 Lankrep fin, Mapei Mapegrout).

See NF standards for concrete repair products to be applied by the structural contractors. They are to be applied in accordance with the manufacturer's instructions and the following requirements:

• Minimum surface cohesion: 1MPa

• Sharply cut edges (using a disc cutter)

• Dampened floor surface

• Surface condition: light mortar skim



Cross section of resin mortar

## 2 SURFACE PREPARATION

### 2. Renovated floor surfaces and preparation of hydraulic concrete surfaces

#### 2.1 BARE OR PAINTED CONCRETE





Prepare as for new floor surfaces

#### 2.2 EXISTING FLOOR COVERING

The criteria for the removal or preservation of an existing floor covering are:

- If the defective area [damaged floor covering, etc.] is < 10% of the total area, keep the old covering
- Beyond 10%, the old covering must be removed completely.

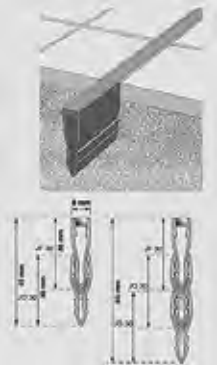
#### a/ Tiles

<p><b>TILES 10X10CM, 15X15CM, 20X20CM</b></p>	<p><b>NB: The larger the tiles, the greater the risk of unevenness between tiles and hollow joints</b></p>	
<p><b>FLATNESS</b></p>	<p>7mm under 2 metres</p>	
<p><b>UNEVENNESS &gt;1MM, JOINTS &gt;4MM WIDE AND/OR 1MM DEEP</b></p>	<p>A light, quick-drying, thixotropic smoothing compound to fill the dips may eradicate the problem, or a grouting compound, e.g., Mapei Ultracolor or Keracolor. Use a squeegee. Avoid build up by sweeping diagonally to the lay of the tiles. Sand down with a fine grit and vacuum clean the dust in order to leave the compound ONLY in the uneven areas.</p>	
<p><b>DEFECTIVE TILES</b></p>	<p>Those few tiles with defects may be removed, together with any areas not adhering to, or not firmly bonded to, the surrounding floor covering. Filling in should be done with a water-resistant resin mortar.</p>	
<p><b>SEPARATING JOINTS</b></p>	<p>The tiles either side of the joint should be examined and tapped lightly. If they are defective (starring, hollow-sounding, etc) they should be removed and replaced, together with any surrounding loose floor covering.</p>	<p>2-part flexible/rigid PVC profile strip. Standard colour: grey (other colours on request). Fire risk category M2 (low flammability). Good resistance to oils, dilute acids &amp; detergents.</p>  <p><b>USE</b> Resilient separation of glued floor coverings.</p> <p><b>DESCRIPTION</b> Rigid profile strip in different heights (8, 10, 12, 14, 16mm), with a central, soft rib.</p> <p> <b>JF 8, JF 10, JF 12, JF 14, JF 16</b></p>
<p><b>SEPARATING JOINTS</b></p>	<p>2-part flexible/rigid PVC profile strip. Standard colours: light grey, white, cream, old wood, clear (rib only). Other colours on request. Fire risk category M2 (low flammability). Good resistance to oils, dilute acids &amp; detergents. Supplied as 30x3 metre strips</p>  <p> <b>JF 30, JO 30</b></p>	<p><b>USE</b> Resilient separation of sealed floor coverings and their mouldings.</p> <p><b>DESCRIPTION</b></p> <ul style="list-style-type: none"> <li>- <b>JF 30</b> (filled) Rigid profile strip 30mm high (overall) with a central, soft rib.</li> <li>- <b>JO 30</b> (open) Rigid profiles strip as JF30 but without the flexible part. JF30s click into JO30s to give 45, 60, 75mm, etc, profile strips.</li> </ul>

## 2 SURFACE PREPARATION

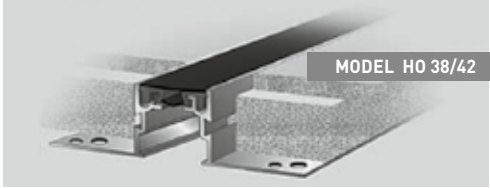
<b>STRUCTURAL EXPANSION JOINT</b>	It must remain connected to the slab. When replacing, use an inset expansion joint, e.g., COUVRANEUF Mifasol HO 38/42, or similar	
<b>FILLING</b>	The floor is then refurbished in layers, either with a levelling compound (with a suitable primer) or with a concrete repair mortar (see NF EN 1504-3).	
<b>SURFACE PREPARATION</b>	The tiles are to be washed with a soda cleaner, rinsed with water and dried.	

### b/ Poured resin floors (epoxy resin only)

Use interior flooring compounds for laying floor coverings.

Undamaged resin floors should be kept and repaired if it is planned to lay a new floor covering as a separate installation.

#### Spot repairs:

The resin can be removed by grinding or sanding followed by vacuum cleaning. It should be patched with an equivalent epoxy type resin.

<b>SURFACE</b>	Floors of poured epoxy resin.
<b>ADHERENCE</b>	No lifting of the resin and defects <10% of the surface area.
<b>FLATNESS</b>	7mm under 2 metres
<b>SPOT REPAIRS</b>	Prepare any cracks with gaps >4mm Prepare any holes or flaking with a diameter >10mm using an equivalent resin to the original.
<b>STRUCTURAL EXPANSION JOINTS</b>	These must remain connected to the slab. When replacing, use an inset expansion joint, e.g., COUVRANEUF Mifasol HO 38/42, or similar
<b>SURFACE PREPARATION</b>	A resin floor may be dry-sanded with a black abrasive disc, a tungsten carbide cutter or a diamond disc. The dust is then removed with an industrial vacuum cleaner.

### c/ Plastic semi-flexible tiles

Use interior flooring compounds for laying floor coverings.

For repairs, floor coverings with underlays must always be removed.

#### • Removing damaged tiles

Those few tiles showing signs of damage can be removed with a hand scraper, together with any surrounding parts no longer glued down.

#### • Filling

The floor is then refurbished in layers, either with a smoothing or levelling compound (with a suitable primer) or with a SIKA type resin mortar (Sikatop 121 Surfacing, Lank 730 Lankrep fin, Mapei Mapegrout).

#### • Surface preparation

The remaining floor covering should be wet-sanded using a black sanding disc. The dust is then removed with an industrial vacuum cleaner.

## 2 SURFACE PREPARATION

<b>SURFACE</b>	Plastic semi-flexible tiles
<b>ADHERENCE</b>	>10%, complete repair. < 10% of the total area, check for adherence. Replace or re-glue non-adherent tiles
<b>FLATNESS</b>	7mm under 2 metres
<b>REMOVING DEFECTIVE TILES</b>	Defective tiles are to be removed together with any non-adherent parts or those not attached to the material below. See regulations above.
<b>STRUCTURAL EXPANSION JOINTS</b>	These must remain connected to the slab. When replacing, use an inset expansion joint, e.g., COUVRANEUF Mifasol HO 38/42, or similar
<b>FILLING</b>	The floor is then refurbished in layers, either with a levelling compound (with a suitable primer) or with a concrete repair mortar (see NF EN 1504-3).
<b>SURFACE PREPARATION</b>	The tiles are to be washed with a soda cleaner, rinsed with water and dried

### d/ Asbestos vinyl tiles

<b>SURFACE</b>	Asbestos vinyl tiles.
<b>ADHERENCE</b>	>10%, complete repair. < 10% of the total area, check for adherence. Replace or re-glue non-adherent tiles.
<b>FLATNESS</b>	7mm under 2 metres.
<b>REMOVING DEFECTIVE TILES</b>	Defective tiles are to be removed together with any non-adherent parts or those not attached to the material below. See regulations above.
<b>STRUCTURAL EXPANSION JOINTS</b>	These must remain connected to the slab. When replacing, use an inset expansion joint, e.g., COUVRANEUF Mifasol HO 38/42, or similar.
<b>FILLING</b>	The floor is then refurbished in layers, either with a levelling compound (with a suitable primer) or with a concrete repair mortar (see NF EN 1504-3).
<b>SURFACE PREPARATION</b>	The tiles are to be washed with a soda cleaner, rinsed with water and dried.

### e/ Other surfaces

Carpets, LVT parquets, foam floor coverings (cushioned or foam-backed vinyls), stratified coverings, linoleum and resins other than epoxy must be removed completely and the floor surface specially prepared to match its condition and the preparation recommendations provided by the supplier of the surface preparation products.

## 3 INSTALLATION

### 1. Storage & work conditions

Before installing the floor covering, it should be inspected for any visual defect. If a visual defect is detected, please inform GERFLOR and do not begin installation without its agreement.



**Ambient temperature**  
Minimum: 10 °C

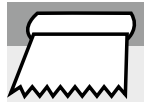

**Subfloor temperature**  
Minimum: 10 °C

Since these shops are climate-controlled, the floor covering is not subject to temperature differences of more than 20°C. Tiles should be stored on site for 24 to 48 hours beforehand at ambient temperature.

**DO NOT MIX THE BATCHES**

### 2. Laying method

GTI / GTI Max Control tiles must be glued down and welded with CR 40 or 50 welding rod. On a perfectly dry surface.

### 3. Detailed laying

#### ■ 3.1 GLUED INSTALLATION WITH EXTRA-WIDE SIFLOOR ADHESIVE STRIP

**Choosing the double-sided adhesive strip according to the surface**

**LAYING SIGAN DOUBLE-SIDED ADHESIVE STRIPS**

SURFACE	PRIMER	TYPE OF ADHESIVE
Water-bound Dryness ratio < 4.5% moisture	PLANUS Only under adhesive D-TACK primer	Sigan 1 D-TACK EXTRA-LAY
Water-bound: Dryness ratio > 4.5%	UZIN EPOXY PE 480 on the entire surface	Sigan 1
moisture	Or Two-part adhesive D-TACK primer	D-TACK EXTRA-LAY
Tiling	NONE	Sigan 2 or 3 DUO-LAY
Resin, Old PVC floor covering	NONE	Sigan 2 DUO-LAY
Vinyl Asbestos tile	NONE	Sigan 2 DUO-LAY

*Sigan 75 x 25 = 20 m<sup>2</sup> - D-TACK 50 x 25 = 12.50m<sup>2</sup>*

• **Note on surface:**

The surface should be dry, hard, perfectly adherent, load-bearing, plane and free from grease, dust and silicone.

Shop windows: In front of large windows, apply Uzin's extra-wide Sigam or D-TACK double-sided adhesive strip (type depending on the surface) (see Table 3.2).

• **If applying primer:**

- Apply evenly to the surface at a coverage of 70 to 100 (max) g/m<sup>2</sup> using a foam roller in two directions at right angles.

- Avoid forming puddles, drops or streaks.

- Allow to dry for 2 hours (at least) in a well-ventilated space.

Primer must be perfectly dry. The drying time depends on the surface, weather conditions and ventilation.

Tiles must not be laid directly on the primer.



- Testing adhesion:  
Roll down the double-sided adhesive strip thoroughly onto the surface. If the double-sided adhesive strip does not stick properly, apply another coat of primer.

• **Laying double-sided adhesive strips:**



- Roll out the double-sided adhesive strip, whilst pressing down lightly with a cork pressing block  
**CAUTION:** The more adhesive (protected) side must never be laid on the floor surface!



## 3 INSTALLATION

- Only roll out the amount of double-sided adhesive strip that can be covered in one day with the floor covering.
- Roll up the remaining the double-sided adhesive strip with the protective paper to protect the surface and the tape from dust.

### • Laying PVC tiles on the adhesive

- Draw guidelines on the protective paper using a chalk line or a pencil
- Mark the start point for the first tiles and the first row of tiles.
- Place a steel rule along the line and cut only the protective paper with a straight blade.
- Remove the protective paper from the adhesive strip, by pulling it in a straight line and keeping it flat. This straight line then forms the start point for the first tiles of the first row.
- Lay the tiles, locking their edges together
- Stack the protective paper as required and then roll it up (to minimise the volume of waste).
- Pull back the protective paper as required, keeping it straight and flat.
- If there is a delay in the laying process, the protective paper can be put back in place to protect the adhesive strips.
- After installation, press down or roll down in two directions, at right angles, all across the floor.

### • Removing tiles and double-sided adhesive strips:

**Double-sided adhesive strips allow you to remove the floor covering without leaving glue traces and without damaging the floor surface.**



- Separate the tiles
- Starting from one corner, separate the double-sided adhesive strip from the floor surface.

- Pull back the floor covering with the double-sided adhesive strip by pulling it flush with the ground

### ■ 3.2 GLUED INSTALLATION WITH POLYURETHANE EPOXY ADHESIVE

- Apply the glue to the surface allowing for the right open time.
- Applying glue to small surfaces lets you lay the planks or tiles without having to kneel or walk on them while the glue is polymerising.
- Avoid applying the glue unevenly
- Comply with spread rates.
- Lay the planks or tiles when the open time has elapsed following the longitudinal axis

- If glue must be applied to larger areas, we recommend only walking on the material after laying load-distribution plates over it.

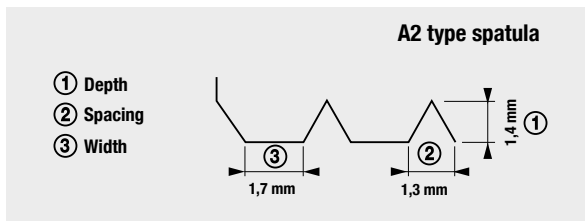

TOOLS	GERFLOR PART NO.
Spatula	0545 0001
A2 planks	0547 0001

- Remove traces of fresh glue as work progresses using solvents recommended by the glue manufacturer.

### Recommended spatula type

### ■ 3.3 SMOOTHING

Smoothing is an important process and must be performed carefully to facilitate the adherence of the glue to the underside of the material.

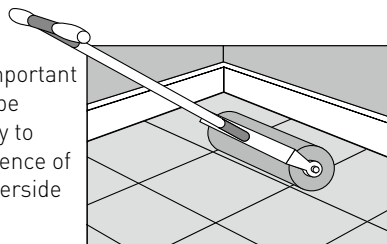

Smoothing using a roller

It is done:

- By running a 45/50 kg (100 lb) smoothing roller over the entire surface in both directions for at least two hours.
- Avoid heavy traffic on the planks or tiles laid recently for 12 hours.

**NOTE:** Any movement or work on the floor covering before the glue hardens must be done using distribution plates or tile setter's shoes.

### • Edge trimming

The tiles are to be laid out such that any cut edges are more than 1/2 tile wide

### Cutting out (procedure, tools, etc.)

- Edge clearance: as standard, the edge clearance is to be 0.5 cm
- Keep a circular saw bench available for use throughout the job.
- Cuts are to be made with a trimming knife (1 cut on the top surface and one on the back) or by overlap cutting (gauging) Overlap cutting: A procedure for marking or cutting out parallel lines. One can use a gauge or a tile.
- Position the tile to be cut on the last full tile laid
- Use an uncut tile as gauge piece
- Place the gauge piece over the tile to be cut, holding it against the wall. Leave 0.5 cm clearance

## 3 INSTALLATION

- Mark the tile to be cut all along the edge of the gauge piece using a knife with a straight blade
- Cut off the part of the tile to be laid neatly and then fit it into place.

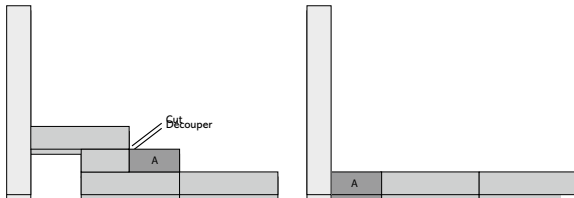

- For awkward areas (door frames, etc.), use high leverage gripper shears.



### Moulting shears with mitre guide

Gerflor : 0566 0001  
Janser : 237 530 000  
To cut around the feet of doorframes and in awkward places.  
Available from Gerflor



### Calliper moulting shears with mitre guide

Janser : 262 284 000  
To cut around the feet of doorframes and in awkward places.

### 3.4 HOT-WELDING OF JOINTS

Joints between tiles are welded using a welding cord (CR 50 by Gerflor).

Because tiles have straight edges, great care must be taken when using the electric chamfering machine to avoid cutting grooves outside the joints.

**To avoid bad welds at the intersections between tiles, the chamfering, welding and trimming operations must all be completed in one direction before doing them in the other.**

Method:

**Chamfering:**

- Chamfer the joints using an electric chamfering machine, blade width 3.3 mm, depth 1.5 to 1.8 mm

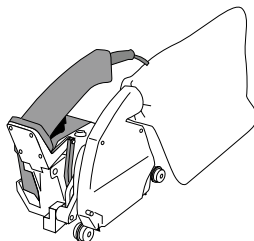

Chamfering machine

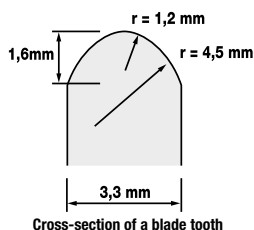

**GTI chamfering**  
Width 3.3 to 2.5 mm  
Depth 1.5 to 1.8 mm

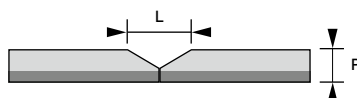

### Hot-weld the joints using a welding trolley

This is done using a LEISTER UNIVERSAL or UNIFLOOR welding machine with an electronically-controlled hot air gun and a multiple-vent narrow nozzle designed for this purpose.

ROMUS	JANSER	LEISTER
95 254	225 860 040	105 407

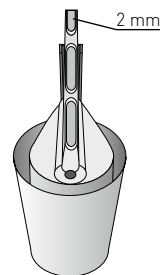

Narrow nozzle

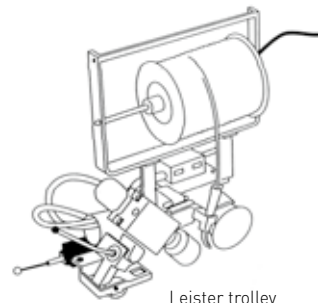

Leister trolley

- Trim the weld seam in two steps once the weld seam has cooled

**Using a MOZART knife:**

First pass:

Rough trim by placing the trimmer guide under the MOZART cutter blade (Fig. 1)

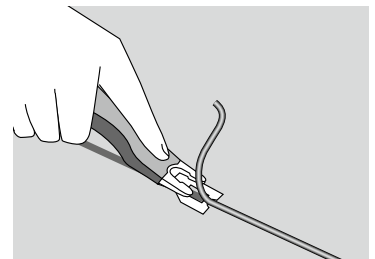

Fig 1. Trimmer guide under blade

Second pass:

(The weld seam must be totally cold):

Turn the trimmer guide through 90° to one side to remove any excess weld seam completely. (Fig. 2).

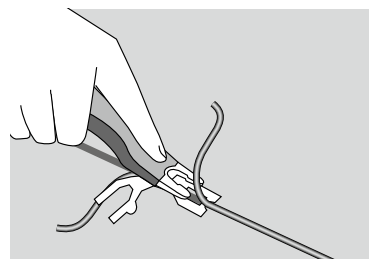

Fig 2. Trimmer guide at 90°

TOOLS	GERFLOR PART NO.
MOZART knife	0561 0001
Spare blades	0542 0001

This trimming method avoids leaving hollow weld seams.

## 4 FINISHING AND JUNCTIONS

### 1. Around pillars

The 5mm edge clearance should be filled with a MS polymer mastic.

This filling may be covered over by a rigid or flexible baseboard.

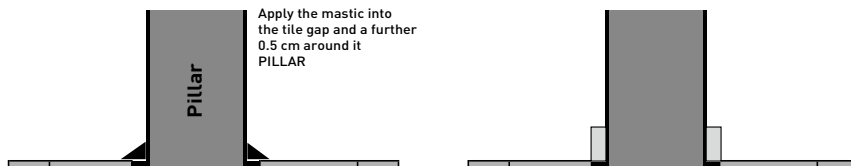

### 2. Along wall edges with an existing baseboard

The 5mm edge clearance should be filled with a MS polymer mastic.

This filling may be covered over by a glue-on rigid or flexible baseboard.

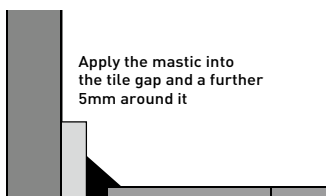

### 3. Along wall edges

The 5mm clearance should be filled with a MS polymer mastic.

This filling may be covered over by a rigid or flexible baseboard.

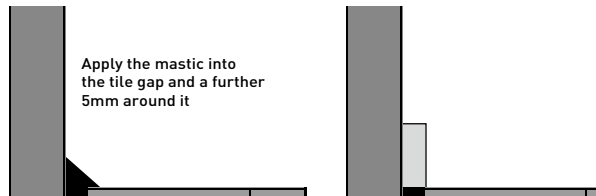

### 4. Around pipe-work and door frames

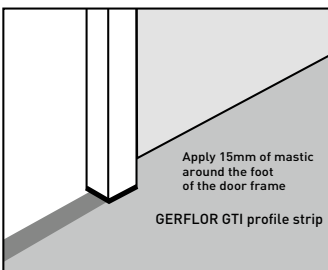

Apply a PU or MS polymer mastic to the cut out clearance.

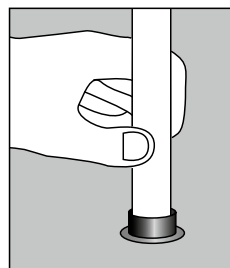

Fill around with MS polymer mastic.

### 5. Laying TBS self-adhesive strips on GTI in front of fruit & vegetables gondolas

If it is liable to be slippery in front of the fruit and vegetables gondolas, we suggest that you apply an anti-slip self-adhesive strip

Length:	10 metres
Width	60cm
Colours	Black C 08
Roll diameter	17cm
Weight/m <sup>2</sup>	2,4kg
Thickness	1,6mm
Best before:	1 year

#### Laying:

- Lay the TBS strip only on GTI or GTI Max tiles
- Tiles must be clean and dry when the strip is laid
- Lay the strip keeping in line with the gondola covering at least one row of dovetail
- Pull off the protective film from the adhesive strip as you work
- Press down the strip with your hand, and then with a smoothing roller

#### Replacing TBS strips (recommended every 6 months)

##### When this strip needs to be replaced:

- Carefully cut 15 to 20 cm wide strips
- Carefully pull out this strip with your hand
- Keep in line with the strip to avoid starting a fracture
- Clean the GTI surface with a power scrubber and an alkaline detergent to remove any adhesive residue

### 6. Joining two 500m<sup>2</sup> sections or changing colours

#### Two options:

#### 1. No problems interlocking tiles across two 500m<sup>2</sup> sections:

Lay out and interlock the tiles using pre-laid extra-wide, double-sided adhesive strips.

#### 2. Non-alignment of tiles across two 500m<sup>2</sup> sections

- Cut off the dovetails, ensuring that the tiles are absolutely square for their full length
- Mark a line 550 mm from the cut with a chalk line
- Lay two longitudinal rows
- Use these two rows to position the tiles to be cut
- Cut the tiles using the gauge piece method but leave 1mm for a hot weld seam
- Continue to lay the tiles ladder-style

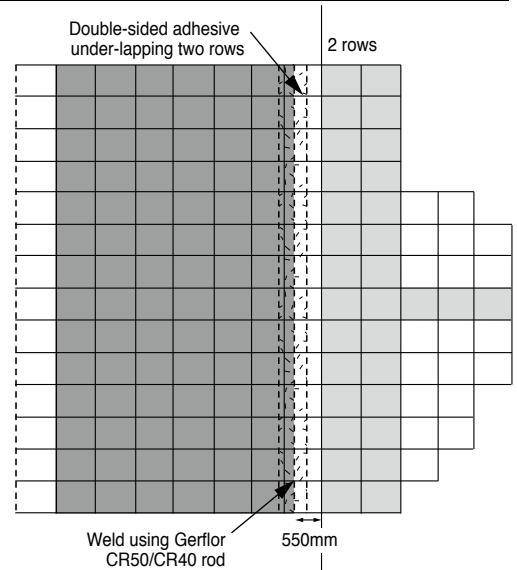

### 7. Intersections between GTI/GTI Max, GTI/ATTRACTION® or GTI Max/ATTRACTION® tiles

- Cut off the dovetails, ensuring that the tiles are absolutely square for their full length
- Mark a line 550 mm from the cut with a chalk line
- Lay two longitudinal rows of the second tile type
- Use these two rows to position the tiles to be cut
- Cut the tiles using the overlap method but leave 1mm for a hot weld seam
- Continue to lay the tiles ladder-style

**NB.** For joints with Attraction® tiles, glue a 1mm tapering edge strip to the GTI or GTI Max side

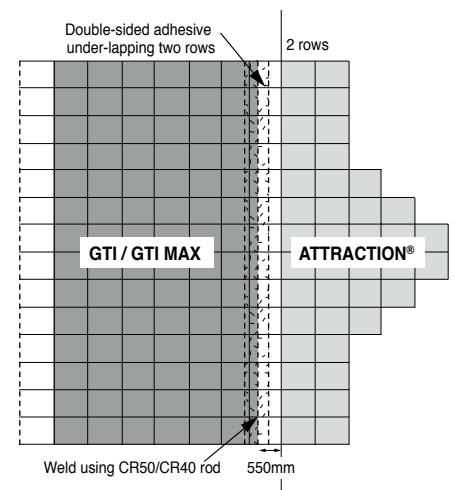

### 8. GTI/GTI Max junction with Creation Clic 70

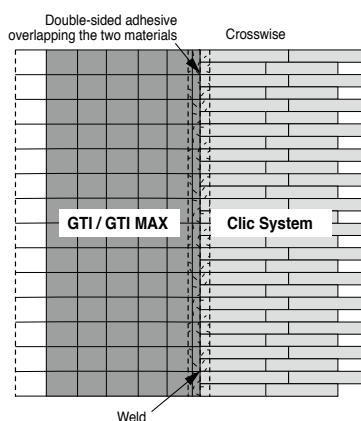

#### 8.1 GTI/GTI MAX/ATTRACTION®/CREATION CLIC 70 CROSSWISE JUNCTION

**GTI / GTI Max / Attraction®:** Cut off the dovetails, and / or leave a maximum gap of 1 mm. Place a double-sided adhesive under the tiles.

**Creation Clic 70:** Cut the boards leaving a maximum gap of 1 mm. Place a double-sided ultra-wide adhesive (SIGAN) overlapping the two materials. Chamfer, weld and trim as per the installation instructions.

## 4 FINISHING AND JUNCTIONS

### 8.2 GTI/GTI MAX/ATTRACTION®/CREATION CLIC 70 LENGTHWISE JUNCTION

#### GTI / GTI Max / Attraction®:

Cut off the dovetails, and / or leave a maximum gap of 1 mm. Place a double-sided adhesive under the tiles.

#### Creation Clic 70:

Cut the boards to eliminate the vertical click-fit.

Place a double-sided ultra-wide adhesive (SIGAN) overlapping the two materials. Chamfer, weld and trim as per the installation instructions.

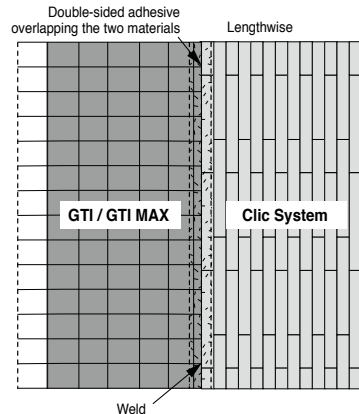

## 9. Junction between tiles or store doorways with Attraction/GTI/GTI MAX

- Install the GTI/Attraction 0505 edge profile, checking that it is attached 5 cm from the edges.
- Stainless steel screws and plugs are supplied with the profiles.

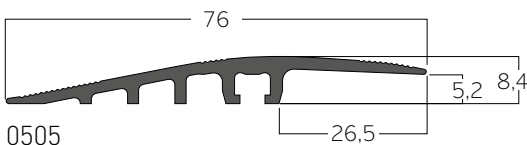

#### 3 metre long profile strip with 9 pre-drilled countersunk holes, 4.3mm diameter.

- The spacing between holes is 313 mm
- The first hole is 90 mm from the end
- The holes are de-burred after drilling

#### 4x50mm TFZ screws and 6x30mm

TFZ 4mm diameter screw, 50mm long



6mm diameter plug, 30mm long

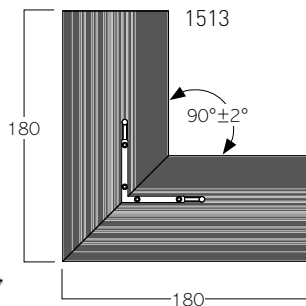

#### Inside corner profile

Packaging: 4

Supplied with 8 screws,

8 plugs and 4 connectors

Dimensions: 180 x 180 mm

## 10. Joints around fixed or un-dismounted cabinets with GTI/GTI Max

Areas around a gondola shelving unit on a concrete or original material covered floor surface



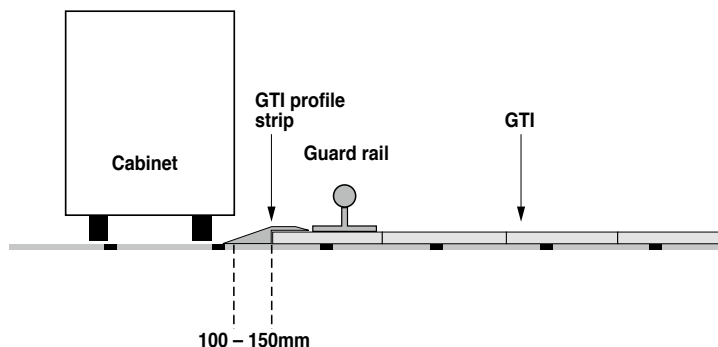





- Cut the tiles to a distance of between 100 and 150mm from the cabinet.
- Install a GTI H202 edging strip, checking that it is attached 50mm from the edges. Use 4x40 or 50mm countersunk, flat and crosshead stainless steel screws and the appropriate plugs for the floor surface.
- It is a good idea to place low guard rails in front of the cabinets.



## 5 FINAL CLEANING

**Commissioning may take place immediately after the installation of the floor covering, however the following points should be observed.**

- The floor covering must be cleaned once the installation work is finished, but no less than 24 hours afterwards
- Remove all dust and off-cuts with a broom and industrial vacuum cleaner
- Wash the floor with a power floor cleaner /scrubber and an alkaline detergent
- Rinse with clean water to eliminate all traces of detergent
- Allow to dry

EQUIPMENT TYPE	CHEMICAL	METHOD	FREQUENCY
<b>INITIAL OR DEEP CLEAN</b>			
 +  Auto-scrubber + Red disk    or  Scrubbing brush Squeegee or Wet vacuum cleaner	<b>Dynatech Trophy</b> 10% solution*	<ul style="list-style-type: none"> <li>• Clean with the auto-scrubber (vacuum suction switched off), and allow the product time to work</li> <li>• Work in strips, overlapping the lines</li> <li>• Vacuum</li> <li>• Finish along the display units with the scrubbing brush + squeegee or wet vacuum cleaner</li> </ul>	As necessary
	<b>Rochex ROCTONIC</b> 3% solution		
	<b>Kiehl DOPOMAT INTENSO</b> 2% solution		
	<b>ECOLAB NEOMAT A</b> 2% - 3% solution		
<b>ENTRETIEN COURANT</b>			
 +  Auto-scrubber + Red disk   Flat mop	<b>Dynatech Trophy</b> 1-2% solution*	<ul style="list-style-type: none"> <li>• Clean with the auto-scrubber</li> <li>• Work in strips, overlapping the lines</li> <li>• Vacuum</li> <li>• Finish along the display units using the flat microfibre mop</li> </ul> <p>⚠ String mops deposit too much residue (product/ water)</p>	Daily
	<b>Rochex ROCTONIC</b> 1% solution		
	<b>Kiehl DOPOMAT INTENSO</b> 0.3% solution		
	<b>ECOLAB MAGIC MAXX</b> 1% solution		

Note: Do not use too much water on the flooring, to avoid water seeping between the tiles  
 \*Distributed by Gerflor - Code: 085E 0001

### MANUFACTURERS' ADDRESSES

#### POWER FLOOR CLEANERS/SCRUBBERS

##### TENNANT

383 rue Belle Etoile  
 95700 Roissy en France  
 Tel. : +33 (0)1.49.90.50.00

##### NILFISK

26 av. de la Baltique BP 246  
 91944 Courtaboeuf Cedex  
 Tel. +33 (0)1 69 59 87 00

#### CLEANING MATERIALS

##### LABORATOIRE ROCHEX

3 avenue des Buchillons BP 263  
 74106 Annemasse  
 Tel. : +33 (0)4.50.37.49.54

##### KIEHL FRANCE

1 rue de l'industrie BP 54  
 67172 Brumath  
 Tel. : +33 (0)3.88.59.52.25

##### ECOLAB

8, rue Rouget de Lisle  
 92442 Issy les Moulineaux  
 Tel. : +33 (0)1.40.93.93.94

For further details, please contact our engineering support department.

## 6 REPLACING FURNITURE

- Consoles (whether stocked or not) and other display units must be put back in place by moving them on Fourmi movers (<http://www.fourmi-distribution.com/>) to prevent slippage of the material.
- **Neither the installers nor the manufacturers will accept any responsibility for damage caused to the floor covering by the replacement of furniture items.**

## 7 RÉPARATION ET MAINTENANCE

### 7.1. Routine inspection, maintenance and repairs

Users must regularly inspect the visual appearance of the work and inform the Client and/or the original installers of any problems that may, in their opinion, lead to a premature failure of the work.

A special survey, where requested from the licensees by the users, should be able to identify the differences between ageing associated with normal wear and tear, traffic and use of the premises, and any damage of an accidental nature.

If the users' observations appear valid after the special survey, the installers will carry out the repair work under their contractual or statutory obligations.

#### COMMENT:

As part of this routine inspection, users should immediately notify any accidents arising from working in the premises and, in particular, any gashes due to dropping sharp instruments, burns, etc, so that repairs can be made.

Such maintenance may be carried out by the user's own maintenance department.

### 7.2. Replacing Attraction® / GTI / GTI Max tiles

#### • Replacing loose-laid tiles

- Cut out one corner of the damaged tile
- Unclip the dovetails
- Replace with a new tile, following the tiles' direction.

#### • Replacing glued-down tiles

- Cut out one corner of the damaged tile
- Unclip the dovetails
- Cut out and replace the adhesive strip
- Replace with a new tile, following the tiles' direction.



## 8

## ENTRANCE MAT INCORPORATING ROMAT GT FROM ROMUS

### EQUIPMENT NEEDED:

Knife with straight blade / Square / Rule / Tape Measure / CORDEX /  
EXAKT Saw circular type DC170 (ROMUS ref: 93891) Screwdriver Torx T10

### 1. Incorporating an Entrance Mat

The installation of the entrance mat is to be performed after completion of the GTI / GTI Max Control tiles.

Identify the area of the entrance mat by drawing a rectangle of 152.5 x 102.5 cm on the GTI / GTI Max Control tiles.

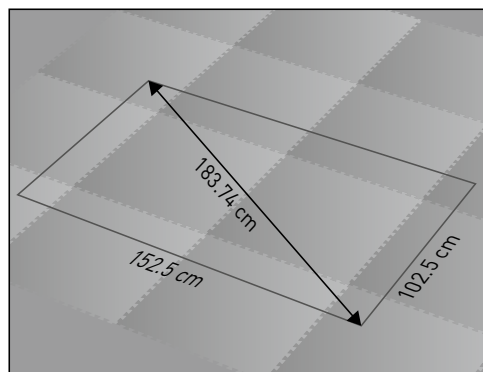

### 2. GTI Removal

Cut along the trace line on the surface of the GTI / GTI Max Control tile with an EXAKT DC170 saw (ROMUS ref: 93891) to a depth of 1mm less than the thickness of the GTI / GTI Max Control tile (eg 5mm versus 6mm for a GTI tile) and stopping at few centimeters from the corners.

Finish cutting the material at the corners with a straight blade knife. Clear the area of material.

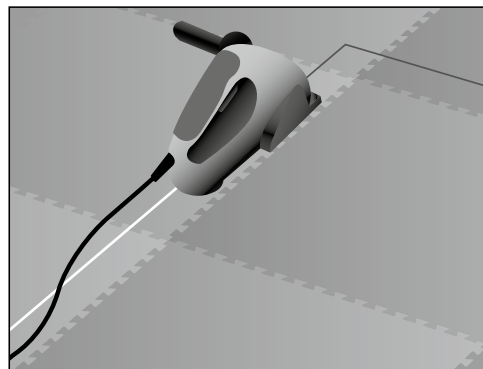

### 3. Setting the Entrance Mat Frame

#### 3.1. PLACING THE BASES

Position the 4 bases under the GTI / GTI Max Control leaving a clearance of 3-5 mm. Leave a 5cm gap at each corner.

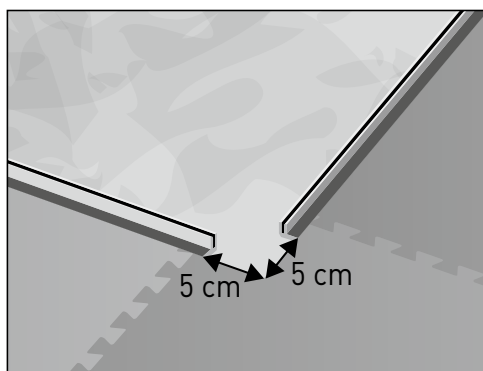
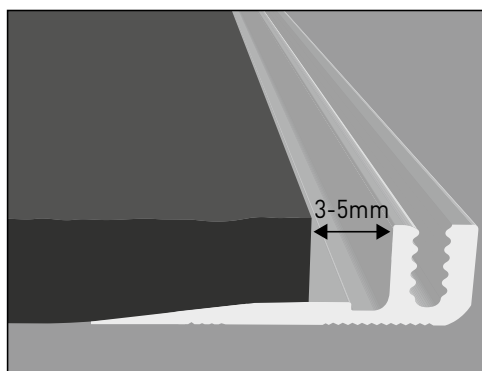



## 8 ENTRANCE MAT INCORPORATING ROMAT GT FROM ROMUS

### ■ 3.2. INSTALLATION OF THE CORNERS

Place the 4 corners loosely in position (Do not fix).

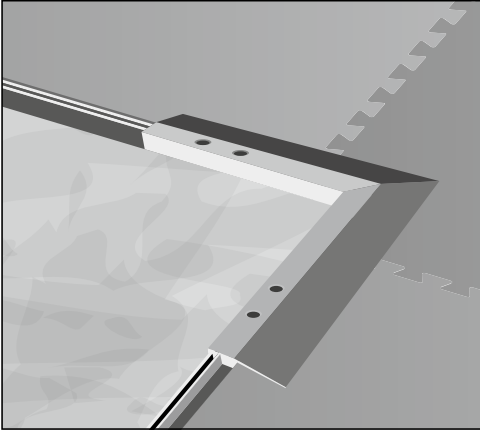

### ■ 3.3. INSTALLATION OF UPPER RAMPS

Position the 4 upper ramps.

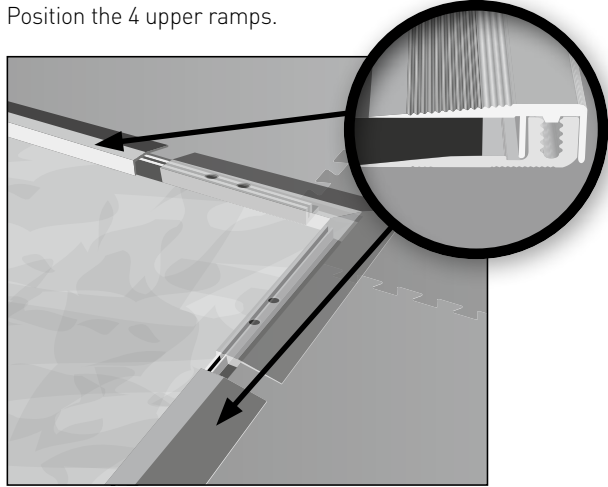

### ■ 3.4. TIGHTENING THE UPPER RAMPS

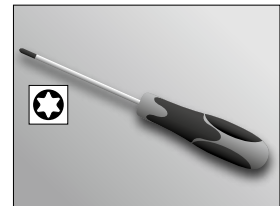
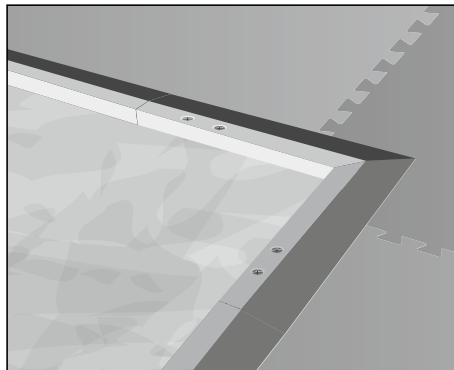
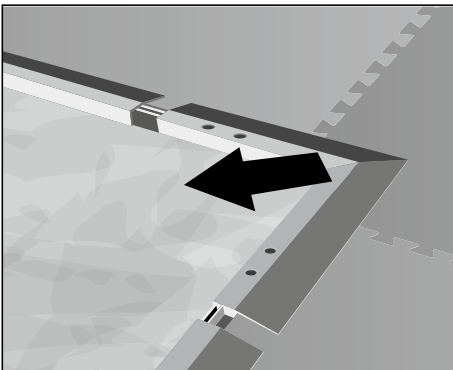

Ensure a tight fit between the 4 corners and the adjoining ramps.  
Screw ramps and corners using a Torx screwdriver (No. 10).

## 4. Setting up the entrance mat in the frame

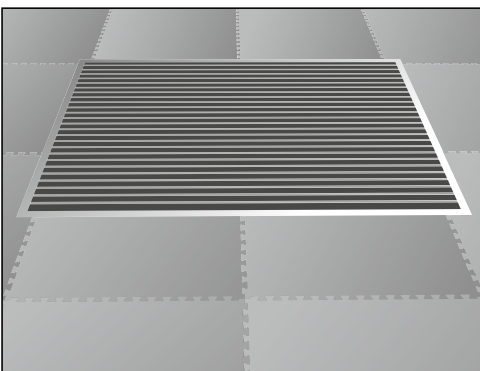

Unroll the pre-made mat into place, ensuring it is square to the area and flat to the floor.

# TARASAFE X-TRA



## TARASAFE X-TRA

---

# TARASAFE X-TRA

## INTRODUCTION

### Warning

Tarasafe X-TRA must compulsorily be laid before GTI / GTI MAX tiles are laid.

Tarasafe X-TRA must be applied to an area larger than the defined area:

Tarasafe X-TRA lengths must be calculated to span the overlap area (an additional 1m around the periphery).

### List of suppliers and special tools

#### JANSER S.A.

Parc d'activités de la Mossig  
B.P. 18 - 67521 MARLENHEIM CEDEX  
Tél. : 03 88 59 28 20  
Fax : 03 88 59 28 22

#### ROMUS

ZA des Pouards 13 et 15 rue du Taillefer  
B.P. 291 - 91162 LONGJUMEAU CEDEX  
Tél. : 01 69 79 69 79 - Fax. : 01 64 48 41 00  
e-mail : commercial@romus.fr

#### WOLFF

4, Avenue du Président COTY  
02880 CROUY  
Tél. : 03 23 76 37 52  
Fax. : 03 23 76 37 51

		GERFLOR	JANSER	ROMUS	WOLFF
	Coffret ABS Lg 410mm		Réf : 226 612 310		
<b>GLUING</b>	Aluminium glue trowel Double toothed trowel 18 cm	0545 0001 + 0547 0001	Réf : 226 331 000 Réf : 226 315 000	94930	967 718 000 977 090 000
<b>SMOOTHING</b>	Cork smoothing wedge		Réf : 262 380 000	93145	720 930 000
<b>MARKING</b>	Skirting marker Rod height set at 200 mm		Réf : 222 430 100	95430	
<b>CUTTING</b>	Utility knife with snap-off blades 9 mm Shears for oblique cuts		Réf : 262 612 310 Réf : 262 280 000	91075 93415	121 700 000
<b>CHAMFERING</b>	Triangular scraper Spare blade Chamfering knife Spare blade Hot grooving gouge 0569 0001	0569 0001	Réf : 262 613 000 Réf : 262 613 001 Réf : 262 610 000 Réf : 262 610 001 Réf : 224 800 009	95178 95179 95160 95161	116 410 000 116 412 000 116 500 000
<b>HOT WELDING</b>	Brass pressure ball Ø13 mm Roller for internal angles Sharpener CLIP DIA Welding roller for beads CR 50 and CA 72	0529 0001 0564 0001	Réf : 224 816 000 Réf : 224 400 123 Réf : 262 891 000 Réf : 262 618 000		116 200 000 116 340 000 511 640 000
<b>COLD WELDING</b>	Cold welder DF type		Réf : 262 675 000	95680	428 080 000

## INTRODUCTION

### Contractor qualifications

#### ■ 1 - CONTRACTOR TRAINING

In view of the intended use, installation must be performed by contractors qualified and trained by the manufacturer and designer of the system.

This methodology will eventually be replaced by the qualification "Laying floor coverings in wet areas" currently in the drafting process.

#### ■ 2 - METHODOLOGY

The method consists in:

- having contractors and personnel recognised by GERFLOR's Technical Assistance department and sales force.
- Assessing and classifying contractors by sector.

Contractors are classified by level:

- Level (A) – contractor qualified to lay Kitchen floor coverings with trained and qualified personnel, the right equipment, and only a small amount of assistance.
- Level (B) – contractor and personnel currently in training, requiring intensive assistance for the 1st installation of the system
- Level (C) – contractor and personnel not proficient in laying the system.

**Only level A or B contractors are approved by GERFLOR.**

#### ■ 3 - CONTRACTOR SUPPORT

- Specification and technical advice supplied
- Collective kitchen laying school (theory and practice)

GERFLOR regularly holds training courses for contractors on laying the system including the following tasks:

- Identifying subfloors, preparing subfloors, gluing and laying coverings, singular points.

#### ■ 4 - QUALITY PLAN CONTENTS

All contractors involved in the installation process must, via a Quality Plan, commit to:

- Contracting and evidencing a special insurance policy for laying floor coverings in collective kitchens,
- Using personnel trained to install all the components of the system,
- Supplying the equipment required to test the subfloor and worksite conditions,
- Performing the inspections prescribed for the methods used for each project,
- Recording, in written form, the information and results of onsite inspections and tests performed for each project.

#### ■ 5 - ARCHIVING WORKSITE FILES

Each worksite file sent in will be filed and archived by GERFLOR.

- Contractor technical assistance
- Contract negotiation support

On request from the approved contractor, GERFLOR is able to provide joint support with co-contractors.

- On-site assistance

Co-contractors, suppliers of the "coating + glue" system and GERFLOR are able to assist the contractor to start up the worksite if requested.

## 1 SCOPE OF USE

SALES AREA	TYPE OF PRODUCTS SOLD	CONDITIONS
FROZEN FOOD	Meats, fish, vegetables, desserts	Areas fitted with siphons designed to accommodate flexible floor coverings
FRESH PRODUCE	Bakery, pastries, spices, dairy cheese, fruit & vegetables, cold meats, delicatessen, poultry	
FRESH PRODUCE	Butchery, fish & seafood	

## 2 SURFACE PREPARATION

### 1. New horizontal surfaces

TYPE OF SURFACE
Slab-on-ground
Floor on concrete slab cast onsite, spanning bearing points
Floors on slab made from prefabricated shuttering slabs and concrete cast onsite, spanning bearing points
Floors made from reinforced concrete hollow-core slabs, with concrete topping spanning bearing points
Floors made from pre-stressed concrete hollow-core slabs, with concrete topping spanning bearing points
Ribbed floors with prefabricated beams combined with cast concrete or other components prefabricated using concrete cast onsite, spanning bearing points
Flooring made from concrete cast on collaborating wide metal profiles, spanning bearing points

### 2. Renovated horizontal surfaces

- Concrete
- Tiling on masonry subfloors
- Resin/Paint
- Flexible floors

**IMPORTANT :** Diagnostics will be performed by the prime-contractor and the recommendations on preparation prior to laying and before levelling will only be confirmed after onsite inspection and an in-depth study of all the data from each project by the surface preparation product supplier's technical departments.

Surface preparation work will only be initiated following written confirmation from the laying contractor's product supplier, observations on the examination of the surface characteristics and precise recommendations on surface preparation.

#### ■ 2.1 - GENERAL REQUIREMENTS

- **Flatness:**

Bowling may not be greater than 3 mm under a 2 m straight-edge.

- **Surface condition:**

Must comply with applicable reference documents.

- **Cleanliness and cohesion:**

Must comply with applicable reference documents. Furthermore, surface cohesion must be equal or greater than 1 MPa, tested by perpendicular traction using a "Sattec" type dynamometer.

- **Porosity:**

Porosity is tested after mechanical preparation; the primer must be suited to surface porosity.

Rising damp: the surface must not be prone to rising damp in any form whatsoever. Refer to standards applicable to the technology used.

## 2 PRÉPARATION DE SUPPORTS

### • **Dryness:**

Maximum residual moisture content in the surface tested using a carbide bomb below a depth of 4 centimetres must be less than 4.5%.

### • **Temperature:**

The temperature of the surface when the covering is laid must comply with your local building standards.

### • **Waterproofing:**

The system meets waterproofing requirements as per cracking and perforation tests except where owners and/or prime-contractors impose specific requirements. (In this event, waterproofing can be provided by an existing single-coat membrane system under the slab, etc...).

### ■ **2.2 - SPECIAL REQUIREMENTS**

Special requirements refer to gradients, base slabs, drainage, possible thermal insulation, altitude and protrusions. In addition, gradients, drainage, base slabs and prefabricated partitions must comply with the description; their number and layout must comply with plans. The systems provided must also be compatible with the waterproofing solution adopted, if relevant.

### ■ **2.3 - PREPARATORY WORK**

Mechanical preparation: proceed with sanding, brushing and/or shot blasting.

#### **Structural joints**

- **Shrinkage joints:** sawn shrinkage joints are treated like cracks, by filling with liquid epoxy.
- **Construction joints:** construction joints are treated like cracks.
- **Expansion joints:** these must be 20 mm wide to accommodate the I profile recommended (see drawing attached); if required, they can be "re-sawn" to the right width. The metal base is screwed onto the surface. Not recommended in cooking or washing areas.

#### **Installing connecting profiles with other coverings**

- **junctions with ceramics:** after sawing the surface to a width of 30 mm, the bottom of the special ceramics junction profile is set in the anchoring resin, the horizontal part being bonded to the surface using the same resin.
- **junctions with resin:** the special resin junction profile is screwed to the surface.

#### **Cracks:**

- Cracks must be treated before applying the primer. Depending on case, they are treated using one of the following techniques:
  - **Hair cracks less than 0.3 mm wide: the entire surface must be treated by applying a primer.**
  - **Cracks equal or wider than 0.3 mm, and less than 1 mm:**

- open up all cracks using an angle grinder with a diamond disk down to approximately half the thickness (in all events at least down to 1/3 of the depth).

At right angles to the cracks, make cross-cuts every 20 to 25 cm for clasps.

- Clear dust from cuts using an industrial vacuum cleaner,
- Install the clasps,
- Fill cracks by saturating with liquid epoxy resin,
- Sprinkle freshly filled areas with silica sand, grain size distribution 0.5-1.2 mm,
- When cured, sweep and remove excess sand using an industrial vacuum cleaner.

### ■ **2.4 - TEMPERATURE-RELATED HAZARDS:**

**Heat:** under hot equipment (cooking devices, etc...) located directly on the ground, an M0 fireproof base must be used to a height of at least 10 cm above the floor covering height.

**Cold:** Only cold rooms operating at positive temperature positive (storage) are referred to by this document.

### ■ **2.5 - STAGNANT WATER HAZARDS:**

Measures must be taken to avoid permanent stagnant water and to allow washing water to drain away.

#### **Drainage:**

With reference to the layout plans and description, the surface must provide the following, located in compliance with contractual documents:

- the correct number of gutters of the required type, with a sloping base; gutters must also be provided under equipment purge points,
- the correct number of inspection holes and siphons of the required type, with the necessary gradients

#### **Gradients:**

With reference to the description in the contractual documents, the surface must have the necessary gradients.

#### **Pipe-work base plates:**

Each group of pipe-work must have been isolated into a masonry base plate.

## 3 INSTALLATION

### 1. Storage and site requirements



**Ambient temperature**  
10° C minimum

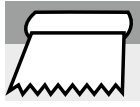

**Floor temperature**  
10° C minimum

Before installing the covering, it should be inspected for any visual defect. If a visual defect is detected, please inform GERFLOR and do not begin installation without its agreement.

#### STORAGE

##### AT AMBIENT TEMPERATURE

- The ambient temperature for installation must be at least +10°C.

#### SURFACE TEMPERATURE

At the time of laying, the surface temperature:

- must be at least equal to +10°C,
- must be 3°C above dew-point, i.e. when airborne moisture begins to condense on the surface or in concrete capillaries.

### 2. Organising the worksite

- Tarasafe X-TRA must be laid before the GTI tiles.
- If, because of site organisation constraints, this can only be completed afterwards, it will be necessary to leave an unfinished area greater than the Tarasafe X-TRA area to allow for overlapping with the GTI tiles.
- Because reactive glues are used, prohibit any traffic during laying and polymerisation of the glue (12h).
- During work, the project owner must make sure that no equipment with rubber foot pads will be stored on the surface.

### 3. Detailed installation information

#### ■ 3.1 - APPLYING COATING MATERIALS

##### GENERAL APPLICATION CONDITIONS

The general condition for applying the coating are those of the Technical Specification for applying smoothing and self-levelling coats for preparing indoor floors for thin coatings. The instructions specific to the product are indicated below.

##### PRIMER APPLICATION CONDITIONS

The primer is then applied to sand-free areas using a high-density foam roller at a rate of 100 to 150 g/m<sup>2</sup>.

Avoid the formation of puddles. Drying time before applying the coating:

- 2 to 4 hours, on an absorbent surface,
- 12 to 24 hours on a non-absorbent surface.

The coating must be applied the next day at the latest after applying the primer.

##### APPLYING THE LEVELLING COAT TO FLAT AREAS

It is intended for application to flat surfaces.

##### Preparing the paste:

- Mixing the powder: the contents of one 25 kg bag in 6 litres of water (i.e. 24% water), while mixing continuously until a consistent, fluid and lump-free paste is obtained,
- mixing equipment: slow-speed electric mixer.

**Application equipment:** skimmer and spatula with an S2 toothed blade for working towards gutters and siphons,

**Consumption:** See coating specifications

##### Coating thickness on application:

- 3 to 10 mm in P3 premises (as a self-levelling coating) and P4 premises.
- 10 to 30 mm (as an intermediate subfloor).

To improve self-levelling and surface finish, roll the coating while still liquid with a large-cell roller.

12 to 24 hours later, perform a Plusficiel sanding (grain 40 to 60) over the surface and vacuum clean.

##### APPLYING THE LEVELLING COAT TO GRADIENTS

This levelling coat is used to build sloped areas around drainage points.

##### Preparing the paste:

- Mixing the powder: the contents of one 25 kg bag in 6 litres of water (i.e. 24% water), while mixing continuously until a consistent, fluid and lump-free paste is obtained. Only mix quantities that can be used within about 15 to 20 minutes.

- mixing equipment: slow-speed electric mixer.

## 3 INSTALLATION

**Application equipment:** skimmer.

**Consumption:** approx. 1.5 kg /m<sup>2</sup> /mm thick.

- Spread out after creating the gradient paths, (according to the gradient plan: locate reference points using, for instance, stainless steel screws in PVC plugs, on "high and low" lines, in one pass if possible).
- Shape and smooth off while avoiding any air bubbles.
- If applied in several passes, apply the next coat while the previous one is still wet, i.e. as soon as it can take traffic; otherwise, apply a layer of primer then a new coat.
- Leave to dry for at least 24 hours at 20°C for a thickness of 3 mm.
- When completely dry, apply the primer before applying the coating.
- Coating drying time: 24 hours for 3 mm thick, at 20°C.

### a) Requirements relative to the surface treated with the levelling coating

#### Flatness

No bowing greater than 3 mm under a 2 m straight-edge.

#### Gradients

- 1% minimum at all points for an overall gradients
- 1% minimum at all points at a distance of at least 50 cm around the outside edges of all drains.

### b) Pipe-work requirements

No perforation may be made in floor covering for pipe-work (mains or drainage). One of the following solutions must be applied:

- Recessing into a partition
- Routing through a service duct
- Routing through an adjacent room
- Routing through a boxed corner
- Ceiling distribution
- For central elements (ovens, sinks, etc...), build masonry bases with anchoring compounds that do not retain water (or, better still, mortar made of resin and silica sand). Height = 13 cm except special cases, depending on height of kitchen elements.
- Either 1 general base accommodating all piping and electric connections.
- Or several islets accommodating groups of pipe-work and/or ducts.

NB: the height of the bases must match the height of the baseboard overlap.

### c) Requirements concerning special equipment

Kitchen equipment and washing fixtures are anchored to walls.

No assembled equipment (contractors must provide for removal/refitting).

### ■ 3.2 - BUILDING MASONRY BASES

Masonry bases are part of the "slab" work package and are made from ready-to-use cements or mortar without water retention.

- Group of pipe-work along wall.

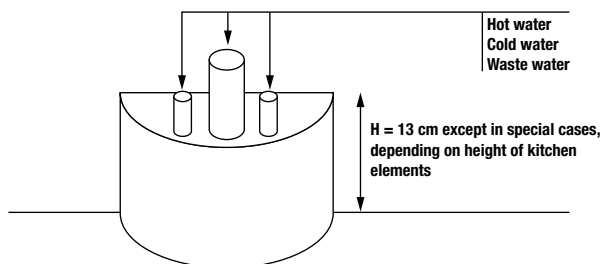

- Accommodating several groups of pipes along a centreline in a rectangular base with rounded corners in the middle of the kitchen or for suspended cooking units.

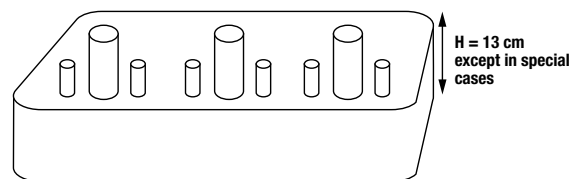

- Group of pipe-work for a single equipment block in the middle of the kitchen.

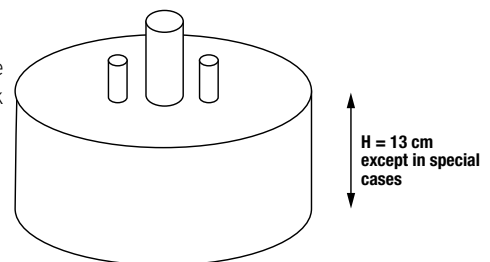



## 3 INSTALLATION

### 3.3 - INSTALLING ACCESSORIES

#### COVING FORM IN FLOOR/WALL ANGLE

**1** Coving form 20 mm

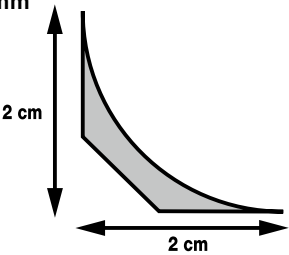

**2** Installing in an internal angle

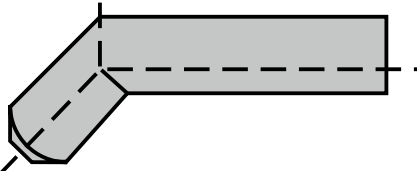

**3** Installing on an external angle

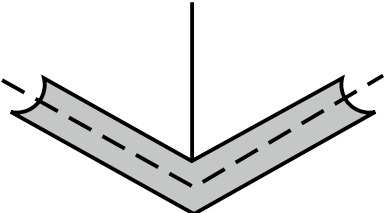

#### CLIP-ON TRIM FOR COVING ON PREFABRICATED PANELS / PAINTWORK

**1**

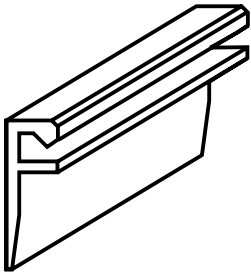

Top of base  
12cm from floor

**2** Installing in an internal angle

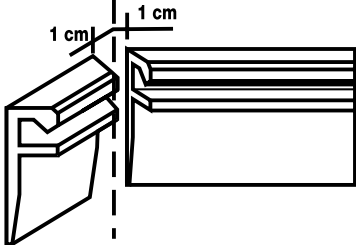

**3** Installing on an external angle

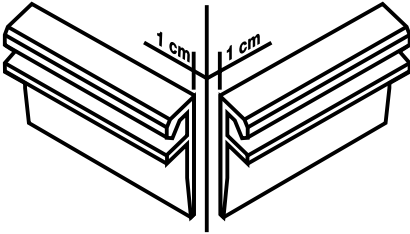

### 3.4 - LAYING THE FLOOR COVERING

#### TARASAFE X-TRA

#### a) Surface

This covering is laid by gluing sections to a surface meeting the applicable standards.

#### b) Laying

##### Installing the material

- Minimum installation room temperature: 10°C
- Minimum surface temperature: 10°C

##### Layout. Preparing sections

- Lay out the sections so that the welds do not encounter siphons and at least 10 cm from gutters.

#### Gluing

##### Use a reactive twin-component glue

- Apply 24 hours after laying out the sections.
- Apply the reactive glue using a fine-tooth spatula type A2 (specification TKB). Consumption: 350 to 400 g/m<sup>2</sup> approx..
- The blade needs changing regularly to comply with this quantity.

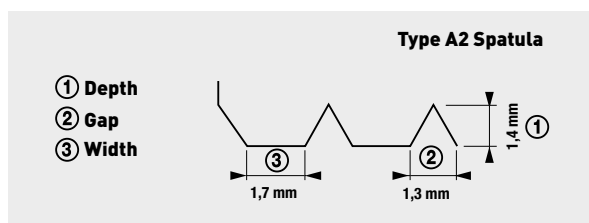

## 3 INSTALLATION

### ⚠ RECOMMENDATIONS FOR GLUING

Follow the glue supplier's instructions carefully, but contrary to the information on the packaging, the quantity to apply is 350 to 400 g/m<sup>2</sup> approx. using a type A2 spatula.

### IMPORTANT

Prohibit any fitting work or furniture installation for 48 hours after laying.

### Applying the sections

- Fold sections halfway back. Apply glue to surface and apply the material.
- Fold back the second halves and proceed as above. Apply the next section with a gap of 1 mm.
- Do not overlap glue films when laying adjacent sections.
- Place ballast around gutters for 24 h before trimming.

### Smoothing

Smoothing technique specific to reactive glues.

- Use a cork smoothing wedge.
- Use weight distribution plates to move around on to prevent glue from creeping.
- Inspect the surface finish of the applied coating regularly [local separation near joints, possible blistering, etc...] and repeat the smoothing operation in necessary.
- Prohibit any traffic during glue polymerisation (12 hours).

### c) Connections between Siphons / gutters and floor covering

Siphon / gutter designed to accommodate PVC floor coverings with rounded angles.

*GRADIENT: 1% minimum at any point spanning a distance of at least 50 cm around the outside edges of each drain.*

*Trim the material around the interior of the cutter, 24 h after gluing and weighing down.*

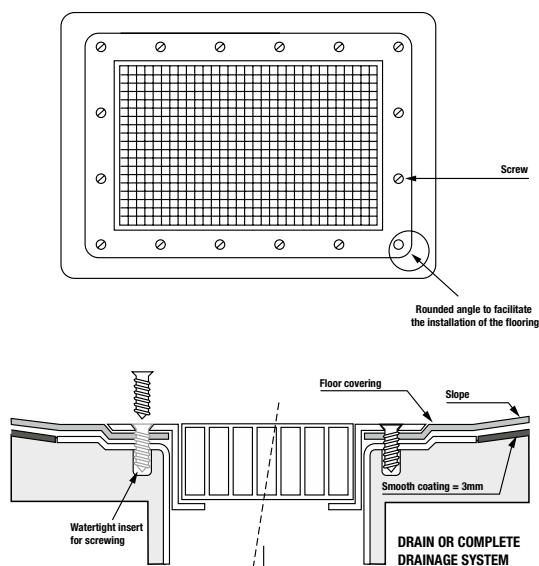

*The use of gutters and siphons specially designed for PVC floor coatings is compulsory. GERFLOR shall accept no liability if this is not the case.*

### Limattec Siphons and Gutters

www.limatec.com

### Bm France Siphons and Gutters

www.blucher.com

### Tournus equipment Siphons and Gutters

www.tournus.com

### Aco Siphons and Gutters

www.aco.com

### Other siphons and gutters (Stainless steel 18/10)

Displaying the same water tightness characteristics can be used (as per warranties given by the supplier with regard to water tightness in connection with PVC floors). For all technical information, please enquire directly with the manufacturers.

### ■ 3.5 - JOINTS

When laying sections, maintain a gap of 1 mm between sections (see drawing)

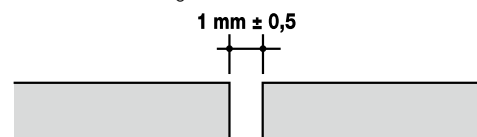

### a) Chamfering

Chamfering opens the joint, makes it regular and removed any traces of glue that might compromise the quality of the weld.

It is performed:



- Manually using a triangular scraper Ref. : 262 613 000
- Mechanically, using a router KFU 1000 E ref.: 223 951 000 fitted with a diamond cutter Ref.: 223 950 300.
- Using a hot grooving gouge Gerflor part number: 0569 0001

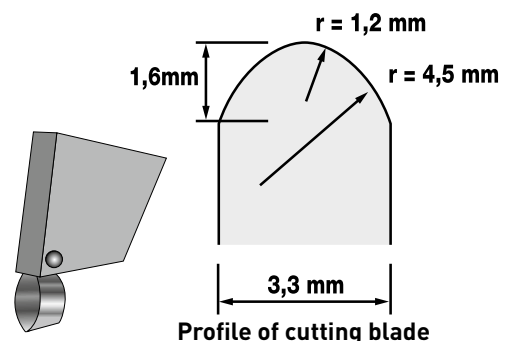

## 3 INSTALLATION

### b) Welding

#### Manual welding

##### A.1: for CR 50 welding rods

Manual welding is done using an adjustable Leister type air blower fitted with a round nozzle and roller or a high-speed (diameter 5 mm).

##### A.2 : for CR welding rods

Use a nozzle and roller

#### Automatic welding

Welding can also be performed using an automatic LEISTER UNIVERSAL welding machine.

### c) Trimming

This operation must be performed in two steps once the weld bead has cooled:

- pre-trimming with a quarter-moon knife and trimming guide.
- finishing using a quarter-moon knife alone or a trimming knife

#### IMPORTANT

GERFLOR is at your disposal for any information concerning the equipment

#### CAUTION!

Feet and coasters: prohibit the use of rubber, which may leave indelible marks.

### ■ 3.6 - WATERPROOFING ON COVING

The floor covering is covered against the baseboard over a coving form.

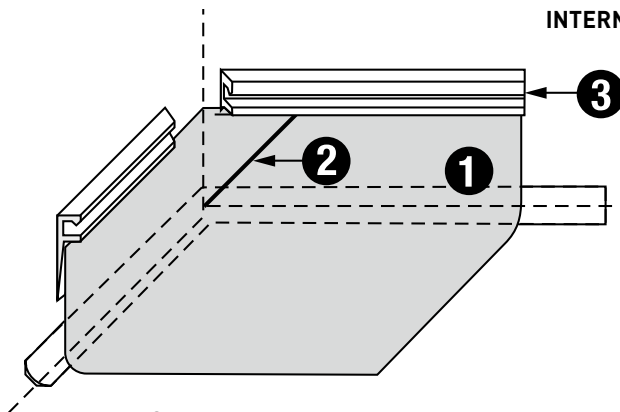

- 1 - TARASAFE X-TRA covered to baseboard  
 2 - Cutting and welding using a CR 50 rod at 45°  
 3 - Base of clip-on trim

#### EXTERNAL ANGLE

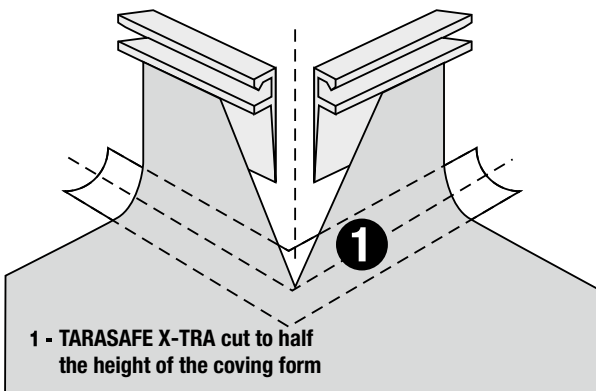

- 1 - TARASAFE X-TRA cut to half the height of the coving form

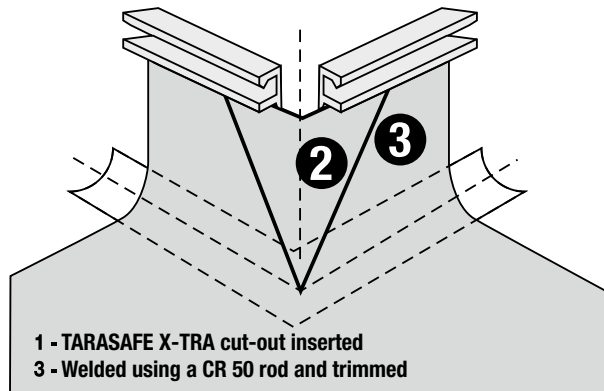

- 1 - TARASAFE X-TRA cut-out inserted  
 3 - Welded using a CR 50 rod and trimmed

## 3 INSTALLATION

### 3.7 - MASONRY BASE PLATES

Group of pipe-work along the wall

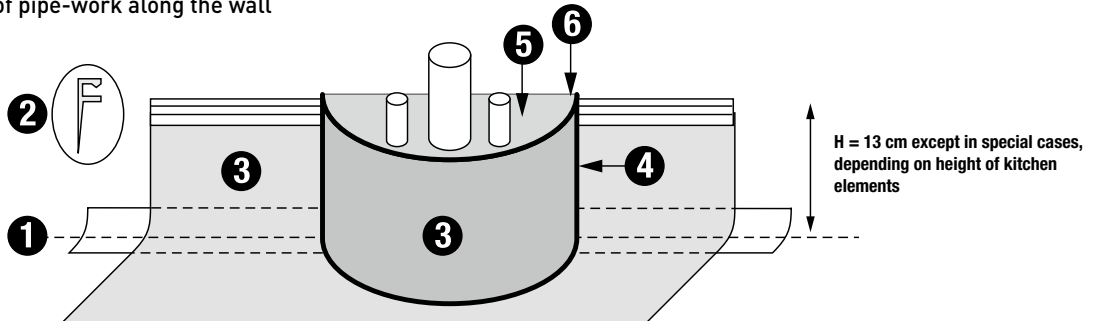

- 1 - Coving form
- 2 - Base of clip-on trim
- 3 - Tarasafe X-TRA cut 1 cm higher than the masonry base

- 4 - Weld using a CA 72 rod with a roller nozzle Gerflor part no. 0564 0001
- 5 - Epoxy mortar cast 5 mm thick
- 6 - Excess material trimmed

Accommodating several groups of pipes along a centreline in a rectangular base with rounded corners in the middle of the kitchen or for suspended cooking units.

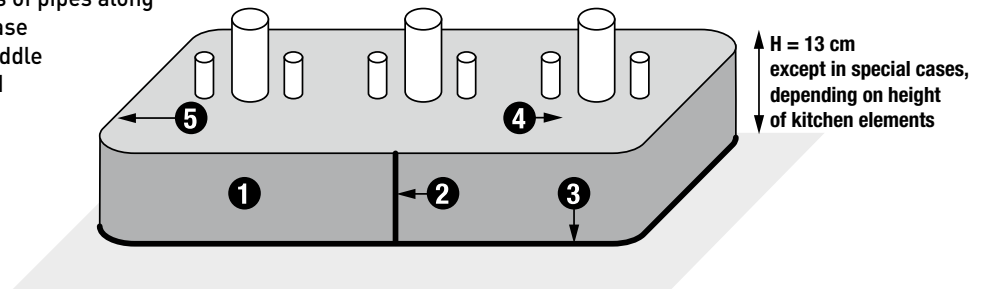

- 1 - Tarasafe X-TRA cut 1 cm higher than the masonry base
- 2-3- Weld using a CR 50 and CA 72 rod with a roller nozzle Gerflor part no. 0564 0001

- 4 - Epoxy mortar cast 5 mm thick
- 5 - Excess material trimmed

Group of pipe-work for a single equipment block in the middle of the kitchen

- 1 - Tarasafe X-TRA cut 1 cm higher than the masonry base
- 2-3- Weld using a CR 50 and CA 72 rod with a roller nozzle Gerflor part no. 0564 0001
- 4 - Epoxy mortar cast 5 mm thick
- 5 - Excess material trimmed

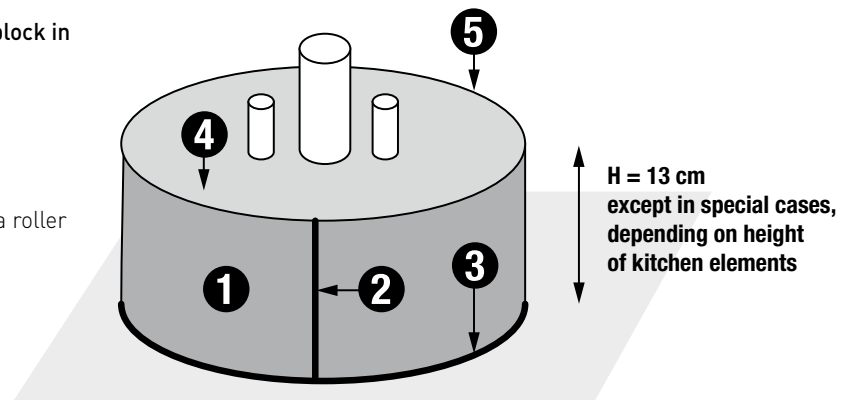

## 4 FINISHING AND JUNCTIONS

### 1. Tarasafe X-TRA / GTI - GTI MAX junction

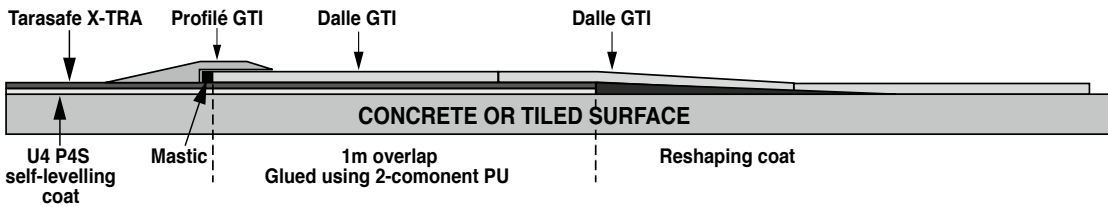
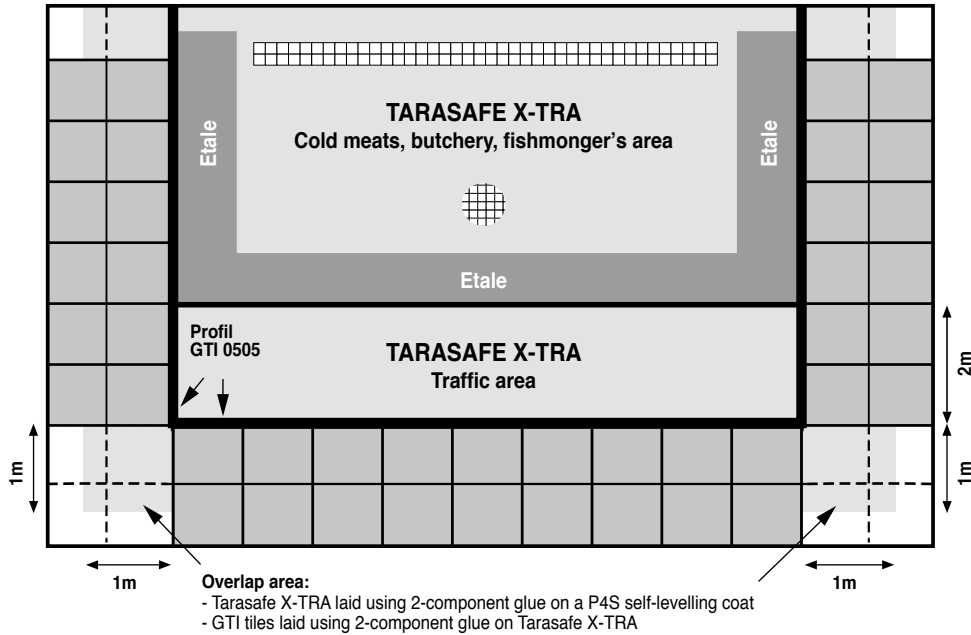

### 2. Tarasafe X-TRA / paintwork (applied to wall) junction

We recommend the use of a GERFLOR clip-on trim

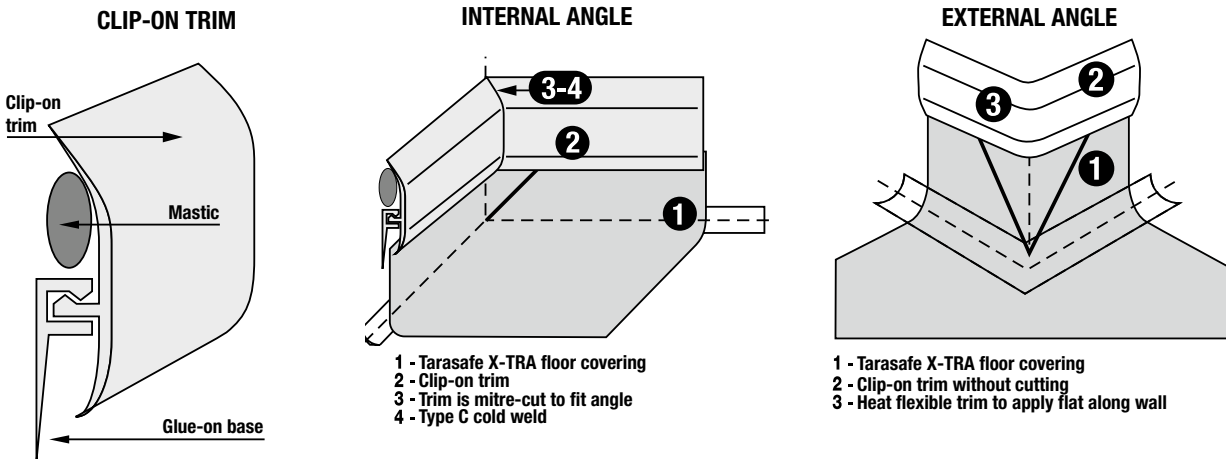

#### UNDERSIDE OF TRIM Preparation

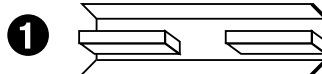

1 - Cut to 3 cm length using shears

### 3. TARASAFE X-TRA / industrial panel junction

- Laying Tarasafe X-TRA before installing prefabricated partitions  
Compulsory floor covering protection

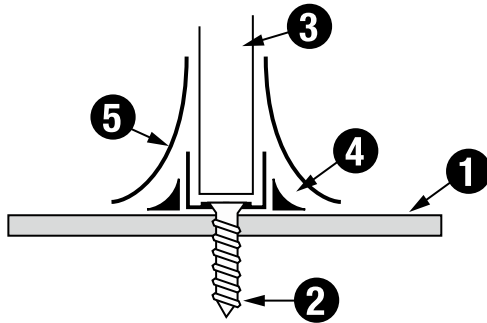

- 1 - Tarasafe X-TRA floor covering
- 2 - Anchoring rails using stainless steel screws and chemical plugs
- 3 - Installing partitions
- 4 - Applying PU mastic along the wall
- 5 - Installing baseboards

- Laying Tarasafe X-TRA after prefabricated partitions are installed

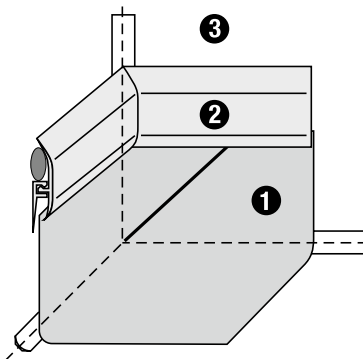

- 1 - Tarasafe X-TRA covering
- 2 - Clip-on trim
- 3 - Industrial panel

#### INTERNAL ANGLE

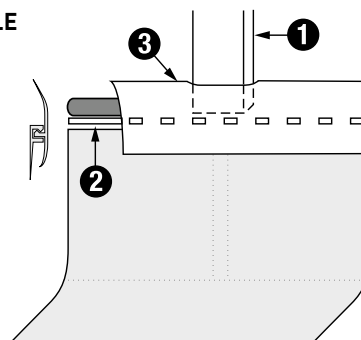

- 1 - Expansion trim strip cut 12 cm above floor
- 2 - Base of clip-on trim installed under the strip
- 3 - Mastic applied and trim clipped on (flexible trim moulds to the shape of the strip)

### 4. TARASAFE X-TRA / tiling junction with partition anchored on tiling

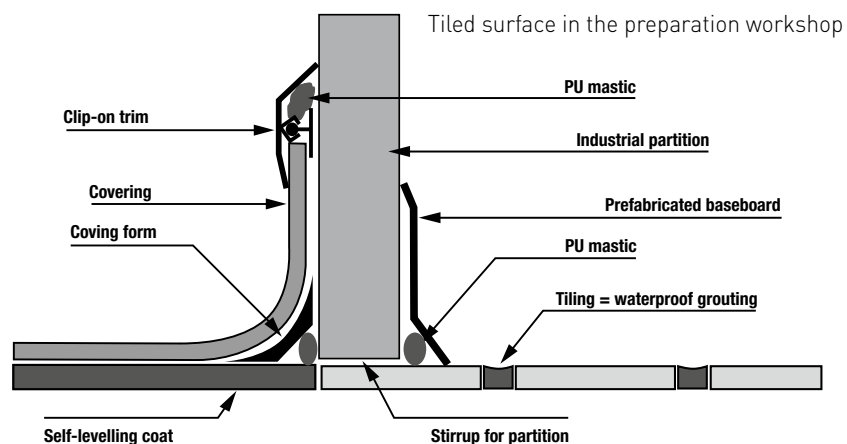

## 4 FINISHING AND JUNCTIONS

### 5. TARASAFE X-TRA / wall tiling junction

#### • Overlap with tiling on covering

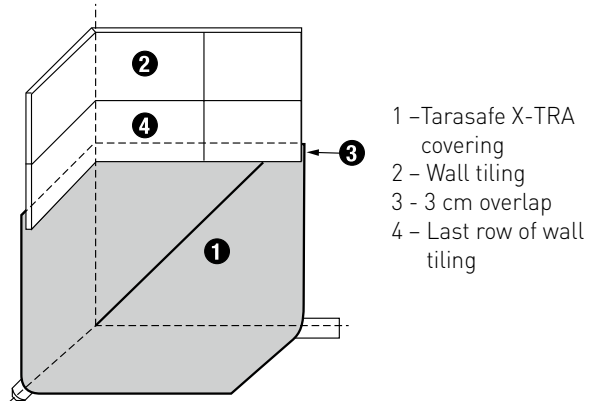
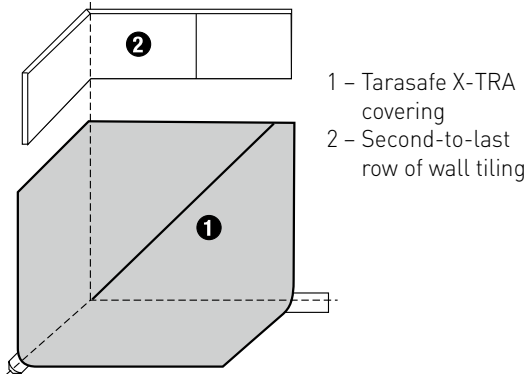

#### • Using a trim strip

The SCHLUTER-type edge trim is installed by the tile-layers during tiling

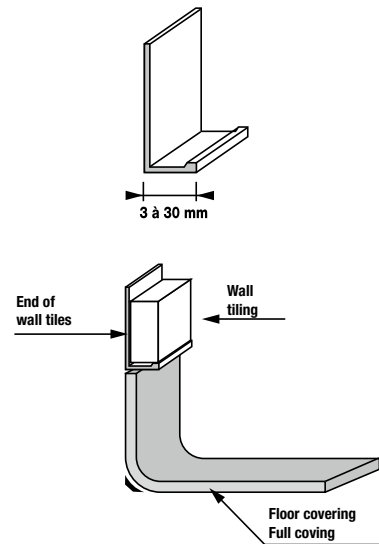
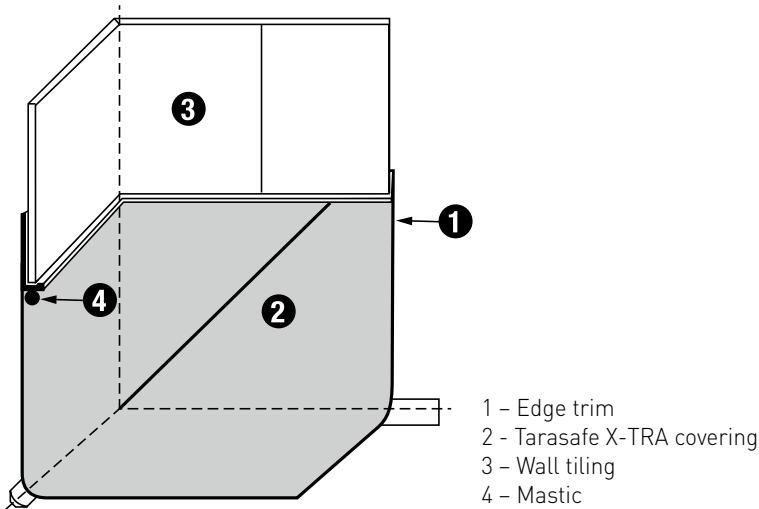

### 6. Singular points

#### ■ 6.1 - DOOR FRAMES

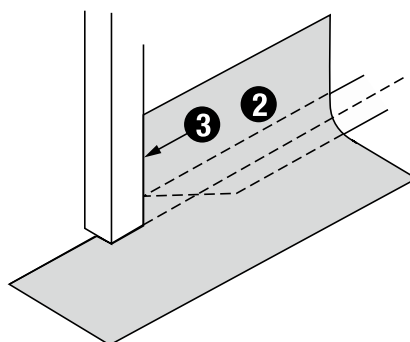
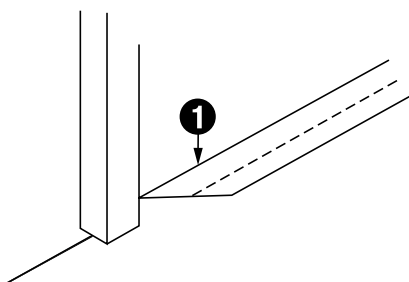

- 1 - Coving form cut at an angle to allow the floor covering to fold down completely against the door frame.
- 2 - Tarasafe X-TRA
- 3 - Mastic

*NB: The foot of the door frame must be cut and treated as a partition head.*

## 4 FINISHING AND JUNCTIONS

### ■ 6.2 - PARTITION HEAD (OR CUT DOOR FRAME)

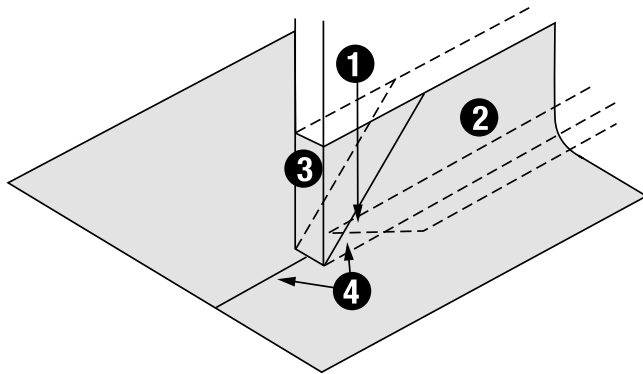

- 1 - Coving form cut at an angle
- 2 - Tarasafe X-TRA
- 3 - Tarasafe X-TRA insert glued on
- 4 - Weld the insert and junctions between sections using a CR 50 rod.

### ■ 6.3 - COVERING THE TOPS OF MASONRY BASES

- 1 - Coving form
- 2 - Clip-on trim
- 3 - Tarasafe X-TRA
- 4 - Weld using a CR 50 or CA 72 rod with a roller nozzle, Gerflor part no: 0564 0001
- 5 - Epoxy mortar cast
- 6 - Excess material trimmed

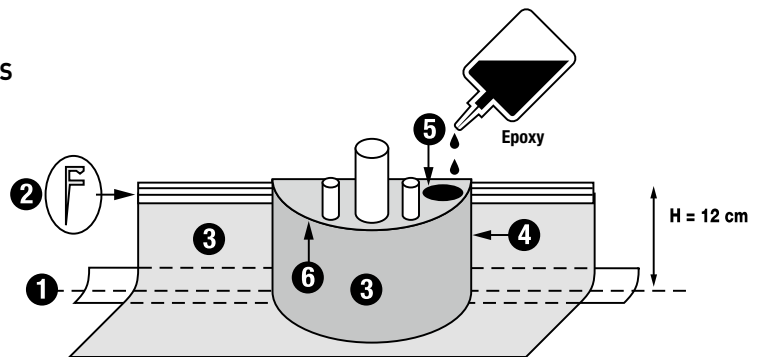

### ■ 6.4 - AROUND DOOR FRAMES

#### • Metal or wood door frames

##### Applying paint

- Thoroughly clean the doorframe to a height of 15 cm.
- Inject PU foam around the door frame
- Apply a 1st coat of waterproof urethane paint
- Leave to dry.
- Lay the Tarasafe X-TRA covering as per specifications.
- Apply the 2nd coat.
- Leave to dry.

##### Peripheral caulking

- Use adhesive tape to mark out the shape of the covering around the foot of the doorframe.
- Apply the Primer 215 - (SIKA) using a brush.
- Leave to dry.
- Apply the mastic: POLYMER MS107 by BOSTIK.
- Carefully smooth the mastic.

##### • P.V.C. door frames

- Use adhesive tape to mark out the shape of the covering around the foot of the doorframe.
- Apply the Primer 215 - (SIKA) using a brush.
- Leave to dry.
- Apply the mastic: POLYMER MS107 by BOSTIK.
- Carefully smooth the mastic.

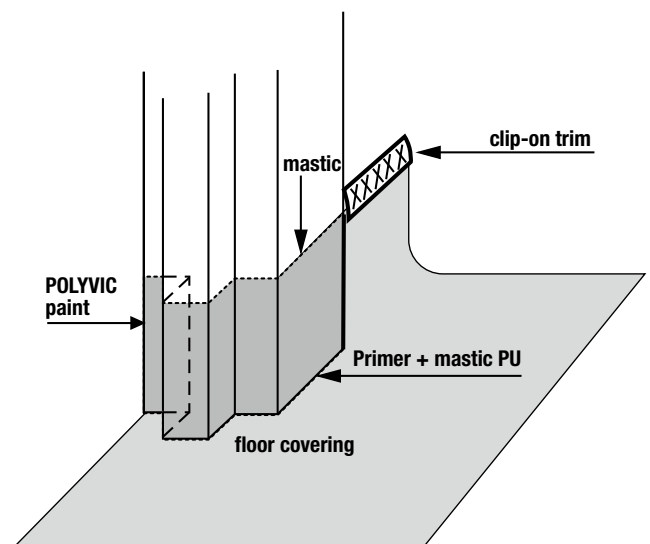



## 5 FINAL CLEANING

- The floor covering must be cleaned once the installation work is finished, but no less than 24 hours afterwards
- Remove all dust and off-cuts with an industrial vacuum cleaner
- Wash the floor with a power floor cleaner /scrubber for PVC floors. Do not use disks.
- Use an alkaline detergent
- Rinse with clean water to eliminate all traces of detergent
- Allow to dry

## 6 REPLACING FURNITURE

- Replacing the display cabinets (empty or full) and other units must only be done no sooner than 24 hours after gluing.
- **Neither the installers nor the manufacturers will accept any liability for damage caused to the floor covering by the replacement of furniture items.**

## 7 REPAIRS AND MAINTENANCE

### Routine inspection

Users must regularly inspect the visual appearance of the work and inform the Client and/or the original installers of any problems that may, in their opinion, lead to a premature failure of the work.

A technical assessment, where requested from the licensees by the users, should be able to identify the differences between ageing associated with normal wear and tear, traffic and use of the premises, and any damage of an accidental nature.

If the users' observations appear valid after the technical assessment, the installers will carry out the repair work under their contractual or statutory obligations.

#### COMMENT:

As part of this routine inspection, users should immediately notify any accidents arising from working in the premises and, in particular, any gashes due to dropping sharp instruments, burns, etc., so that repairs can be made.

CREATION CLIC 70



## CREATION CLIC SYSTEM

---

## 1 SCOPE OF USE

SALES AREA	TYPE OF PRODUCTS SOLD	CONDITIONS
LEISURE	TV, telephony, desktop computing, stationery, books, CD/DVDs, video games	- Foot traffic Trolleys - Hand-wheeled trolleys - Hand pallet trucks max. load 700kg
CHILDREN	Girls and boys aged from 3 to 14, toys	
BABY	Baby food, hygiene, accessories, clothes, equipment	
CRECHE	Child minding facilities	
BEAUTY CARE	Everyday care, make-up, hair colour product, perfumes, jewellery, health/well-being	
FASHION	Women's, men's, underwear	
ORGANIC	Grocery, fresh produce	

### Comments

It is mandatory to glue down Creation Clic 70 on 100% of the surface with a "dry adhesive such as double-sided adhesive strip".

L'utilisation de transpalettes ou autres engins mécaniques est à proscrire systématiquement car susceptible d'engendrer des désordres irréremédiables.

# CREATION CLIC 70

## 1 SCOPE OF USE

### INTRODUCTION: CONDITIONS FOR USE

	STATIC LOAD RESISTANCE		
	MAXIMUM PRESSURE	EQUIVALENT FOR MECHANICAL HANDLING EQUIPMENT	
<b>BONDED CLIC SYSTEM</b>	< 30 kg / cm <sup>2</sup>	< 200 kg / Wheel or bearing point	The wide range of available mechanical handling equipment, cabinets and floor cleaners must comply with various factors such as: size and shape of cabinet feet, type and configuration of vehicle wheels (single or double), their hardness, the mechanical handling system, acceleration & braking systems.

### RESISTANCE TO DYNAMIC LOADS

#### Manutention

Hand-wheeled trolleys, hand pallet trucks maximum load 700 kg

## 2 SURFACE PREPARATION

See chapter 2 "Surface Preparation" page 6 to 10.

## 3 INSTALLATION



Ambient temperature  
Min. 10°C



Laid on long double-sided  
adhesive strips

Before installing the covering, it should be inspected for any visual defect. If a visual defect is detected, please inform GERFLOR and do not begin installation without its agreement.

### 1. Positioning extra-wide double-sided adhesive strips

#### LAYING DOUBLE-SIDED ADHESIVE STRIPS

SURFACE	PRIMER	TYPE OF ADHESIVE
Hydraulic cement Dryness ≤ 4.5% moisture (CCM)	PLANUS only under the adhesive	Sigan 1 from Sifloor
	Primer for hydraulic subfloor	Fix&Free from Gerflor
Hydraulic cement Dryness: Moisture content between 4.5 and 7% (CCM)	EPOXY PE 480 UZIN over the whole area	Sigan 1 from Sifloor
	Primer which can accept up to 7% CCM apply only under double side tape adhésif	Fix&Free from Gerflor
	No	2 part glue
Tiles	No	Sigan 2 or 3 from Sifloor
		DUO-LAY D-TACK
		Fix&Free from Gerflor
Resin, old PVC covering	No	Sigan 2 from Sifloor
		DUO-LAY D-TACK
		Fix&Free from Gerflor

Sigan 75 x 25 = 20 m<sup>2</sup> - D-TACK 100 x 25 = 25 m<sup>2</sup>

## 3 INSTALLATION

### • Note on surface:

The surface should be dry, hard, perfectly adherent, load-bearing, plane and free from grease, dust and silicone.

Shop windows: In front of large windows, apply Uzin's extra-wide Sigan or D-TACK double-sided adhesive strip (type depending on the surface) or Fix & Free from Gerflor (see Table).

### • If applying primer:

- Apply evenly to the surface at a coverage of 70 to 100 (max) g/m<sup>2</sup> using a foam roller in two directions at right angles.
- Avoid forming puddles, drops or streaks.
- Allow to dry for 2 hours (at least) in a well-ventilated space. Primer must be perfectly dry. The drying time depends on the surface, weather conditions and ventilation. Tiles must not be laid directly on the primer.



- Testing adhesion: Roll down the double-sided adhesive strip thoroughly onto the surface. If the double-sided adhesive strip does not stick properly, apply another coat of primer.

### • Laying double-sided adhesive strips:

- Roll out the double-sided adhesive strip, whilst pressing down lightly with a cork pressing block.
- CAUTION:** The more adhesive (protected) side must never be laid on the floor surface!
- Only roll out the amount of double-sided adhesive strip



- that can be covered in one day with the floor covering.
- Roll up the remaining the double-sided adhesive strip with the protective paper to protect the surface and the tape from dust.

### • Laying PVC tiles on the adhesive:

- Draw guidelines on the protective paper using a chalk line

or a pencil.

- Mark the start point for the first tiles and the first row of tiles.
- Place a steel rule along the line and cut only the protective paper with a straight blade.
- Remove the protective paper from the Sigan adhesive strip, pulling it in a straight line and keeping it flat. This straight line then forms the start point for the first tiles of the first row.
- Lay the tiles, locking their edges together.
- Stack the protective paper as required and then roll it up (to minimise the volume of waste).
- Pull back the protective paper as required, keeping it straight and flat.
- If there is a delay in the laying process, the protective paper can be put back in place to protect the adhesive strips.
- After installation, press down or roll down in two directions, at right angles, all across the floor.

### • Removing tiles and double-sided adhesive strips:

- Double-sided adhesive strips allow you to remove the floor covering without leaving glue traces and without damaging the floor surface.
- Separate the tiles.
- Starting from one corner, separate the double-sided adhesive strip from the floor surface.
- Pull back the floor covering with the double-sided adhesive strip by pulling it flush with the ground.



## 3 INSTALLATION

### 2. Laying the boards

#### 2.1. INSTALLATION CONDITIONS

The boards must be stored in the target premises at least 24 hours before laying (minimum ambient temperature 10° C). Mix boards from several boxes of the same series to avoid colour differences.

Room temperature during installation must be at least 10°C.

#### 2.2. SURFACE LAYOUT

- Each sales area is dealt with separately.
- Boards must belong to the same batch.
- The contractor must draft a board layout plan to meet the following requirements:
  - The boards must be laid out in the direction of traffic on a priority basis.
  - Board length at the ends of runs must be > 25 cm.
  - Board lengths and staggering must be > 25 centimetres.

#### 2.3. PLOTTING THE CENTRELINE

Plot the centreline taking into account a balanced cutting scheme on each side.

#### 2.4. GLUED INSTALLATION

- Two methods are possible:

#### 2.5. CUTTING IN (INSTRUCTIONS, TOOLS, ETC.)

- Peripheral cuts are done using the plank and spacer method.
- Cut using a utility knife:
  - Score the surface of the board with a straight blade.
  - Bend the board to break it.
  - Eliminate burs with a hooked blade
- Never leave tongues on peripheral boards.

#### 2.6. INTERLOCKING CONDITIONS (INSTRUCTIONS, TOOLS, ETC.)

- Check there are no burs in the machined groove before snap fitting.
- Locate the groove opposite the tongue.
- Interlock the boards:

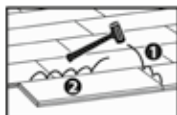

- By tapping with a synthetic mallet crosswise and then lengthwise

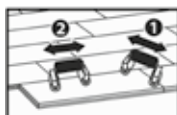

- For lengths, using a pressure roller.



#### Required tooling:

Utility knife – Tape measure  
Metal straight edge - Metal roller  
Dead blow hammer - LVT-Clic Roller

#### 1<sup>st</sup> method:

- Aligning joints every three rows. Stagger rows one third of the board length.
- At ends of rows, board length must be > 25 cm.

#### 2<sup>nd</sup> method:

- Random length strips. Start the 2nd row with the surplus from the previous row.
- Board lengths and staggering must be > 25 centimetres.

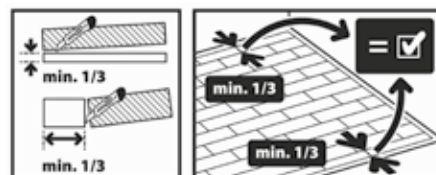
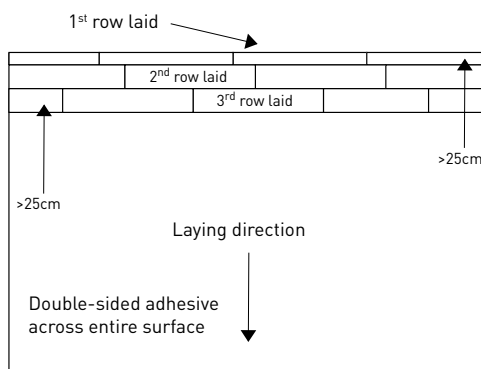

	ROMUS	GERFLOR
Dead blow hammer	94964	-
LVT-Clic Roller	-	058V0001



Dead blow hammer

LVT-Clic Roller

## 4 FINISHING AND JUNCTIONS

### 4.1. BASEBOARDS

If the covering is laid before the baseboards, GERFLOR recommends the use of Vynaflex-type or Gerflor Flexible Baseboard for floor-wall finishing.

In renovation work or if baseboards have already been installed, GERFLOR recommends the use of a quarter round on wooden baseboards or mastic to prevent any water penetration.

### 4.2. CONCRETE EXPANSION JOINTS

- Joints without level difference: The profile of CJ 20-5 ROMUS or equivalent is suitable.

- Joints overlapping profile: The profile is of increased thickness on the coating and is relied on one side.

### 4.3. STOPS

Use a GTI/Attraction 0505 finishing profile

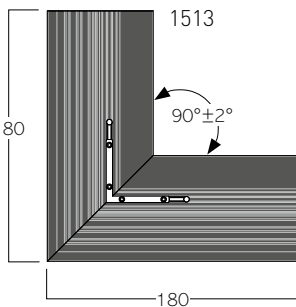
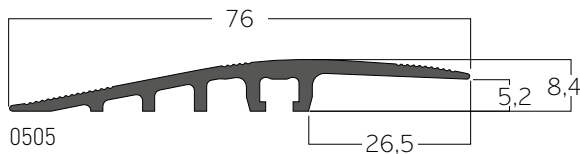

#### Inside corner profile

Packaging: 4

Supplied with 8 screws, 8 plugs and 4 connectors

Dimensions: 180 x 180 mm

#### TFZ 4x50 mm screw and 6x30 mm plug

TFZ 4mm diameter screw, 50mm long

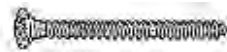

6mm diameter plug, 30mm long



### 4.4. AROUND PIPE-WORK AND DOOR FRAMES

- Use calliper-type or other shears to cut the boards



To cut around the feet of doorframes and in awkward places.

Available from Gerflor

#### Shears with mitre guide

Reference: Romus: 93415 /

Janser: 237 530 000



To cut around the feet of doorframes and in awkward places.

#### Calliper moulding shears with mitre guide

Janser : 262 284 000

- Apply a PU or MS polymer mastic to the cut out clearance

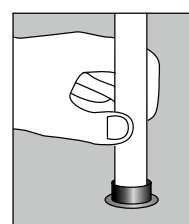
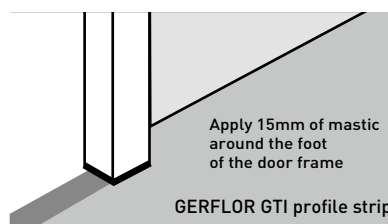

Fill around with MS polymer mastic

### 4.5. AROUND PILLARS

The 0.5 cm edge clearance should be filled with a MS polymer mastic.

This filling may be covered over by a rigid or flexible baseboard.

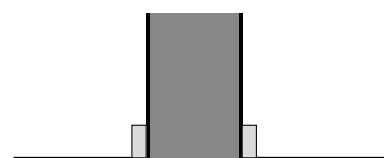
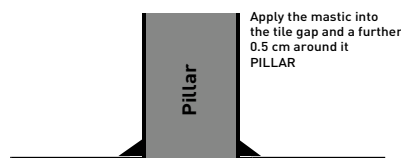

## 4

## FINISHING AND JUNCTIONS

### 4.6. ALONG WALL EDGES WITH AN EXISTING BASEBOARD

The 0.5 cm edge clearance should be filled with a MS polymer mastic.

This filling may be covered over by a glue-on rigid or flexible baseboard.

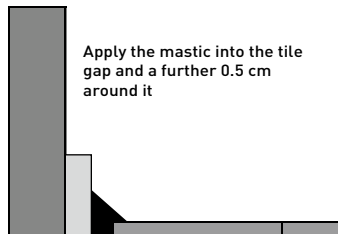

### 4.7. ALONG WALL EDGES

The 0.5 cm clearance should be filled with a MS polymer mastic.

This filling may be covered over by a rigid or flexible baseboard.

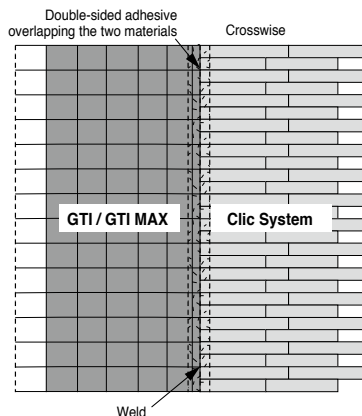
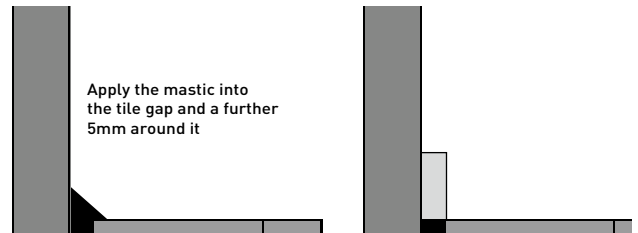

### 4.8. GTI/GTI MAX/ATTRACTION®/CREATION CLIC 70 CROSSWISE JUNCTION

**GTI / GTI Max / Attraction®:** Cut off the dovetails, and / or leave a maximum gap of 1 mm. Place a double-sided adhesive under the tiles.

**Creation Clic 70:** Cut the boards leaving a maximum gap of 1 mm. Place a double-sided ultra-wide adhesive overlapping the two materials. Chamfer, weld and trim as per the installation instructions. CR 50 welding (in key)

### 4.9. GTI/GTI MAX/ATTRACTION®/CREATION CLIC 70 LENGTHWISE JUNCTION

**GTI / GTI Max / Attraction®:**

Cut off the dovetails, and / or leave a maximum gap of 1 mm. Place a double-sided adhesive under the tiles.

**Creation Clic 70:**

Cut the boards to eliminate the vertical click-fit.

Place a double-sided ultra-wide adhesive overlapping the two materials.

Chamfer, weld and trim as per the installation instructions.

CR 50 welding (in key)

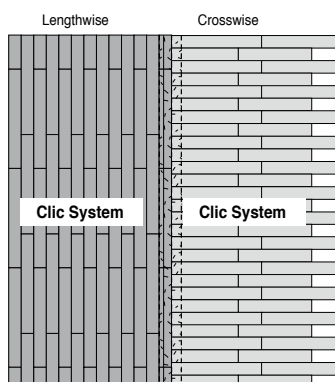
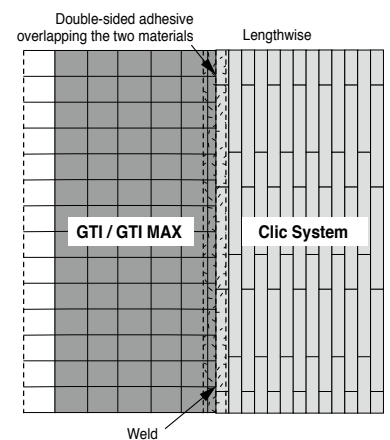

Possible Lengthwise / Lengthwise

### 4.10. EXTENSION IN CREATION CLIC 70

THE SERIAL NUMBERS ARE DIFFERENT, IT IS NOT POSSIBLE TO CLIP THE PLANKS OR TILES TOGETHER. IN THAT CASE:

#### 1. Preparation of PLANKS OR TILES already laid

Remove the finishing profil.

Remove the last row.

If part A of the clip row is visible, cutting it.

Clean the subfloor.



#### 2. Implementation of new planks or tiles

Put a double-sided adhesive on the entire surface to be covered.

1<sup>st</sup> row:

Position part B of the new planks or tiles along the already install row.

Note: You must always leave with part A in front of you.

If the planks or tiles are welded, leave a space of 1 mm for chamfering.











# CREATION CLIC 70

## 5 FINAL CLEANING

**Commissioning may take place immediately after the installation of the floor covering, however the following points should be observed:**

- The floor covering must be cleaned once the installation work is finished, but no less than 24 hours afterwards
- Remove all dust and off-cuts with a broom and industrial vacuum cleaner
- Wash the floor with a power floor cleaner /scrubber and an alkaline detergent
- Rinse with clean water to eliminate all traces of detergent
- Allow to dry

EQUIPMENT TYPE	CHEMICAL	METHOD	FREQUENCY
<b>INITIAL OR DEEP CLEAN</b>			
 +  Auto-scrubber + Red disk    or  Scrubbing brush Squeegee or Wet vacuum cleaner	<b>Dynatech Trophy</b> 10% solution*	<ul style="list-style-type: none"> <li>• Clean with the auto-scrubber (vacuum suction switched off), and allow the product time to work</li> <li>• Work in strips, overlapping the lines</li> <li>• Vacuum</li> <li>• Finish along the display units with the scrubbing brush + squeegee or wet vacuum cleaner</li> </ul>	As necessary
	<b>Rochex ROCTONIC</b> 3% solution		
	<b>Kiehl DOPOMAT INTENSO</b> 2% solution		
	<b>ECOLAB NEOMAT A</b> 2% - 3% solution		
<b>ENTRETIEN COURANT</b>			
 +  Auto-scrubber + Red disk   Flat mop	<b>Dynatech Trophy</b> 1-2% solution*	<ul style="list-style-type: none"> <li>• Clean with the auto-scrubber</li> <li>• Work in strips, overlapping the lines</li> <li>• Vacuum</li> <li>• Finish along the display units using the flat microfibre mop</li> </ul> ⚠ String mops deposit too much residue (product/water)	Daily
	<b>Rochex ROCTONIC</b> 1% solution		
	<b>Kiehl DOPOMAT INTENSO</b> 0.3% solution		
	<b>ECOLAB MAGIC MAXX</b> 1% solution		

Note: Do not use too much water on the flooring, to avoid water seeping between the tiles  
\*Distributed by Gerflor - Code: 085E 0001

## 6 REPLACING FURNITURE

- Replacing the display cabinets (empty or full) and other units must be done by first placing slider boards down to avoid disturbing the loose-lay floor covering.
- **Neither the installers nor the manufacturers will accept any liability for damage caused to the floor covering by the replacement of furniture items.**

## 7 REPAIRS AND MAINTENANCE

### ■ 7.1 - IN CASE OF DAMAGE OR BREAKING OF THE TONGUE (small side) of a plank or several planks:

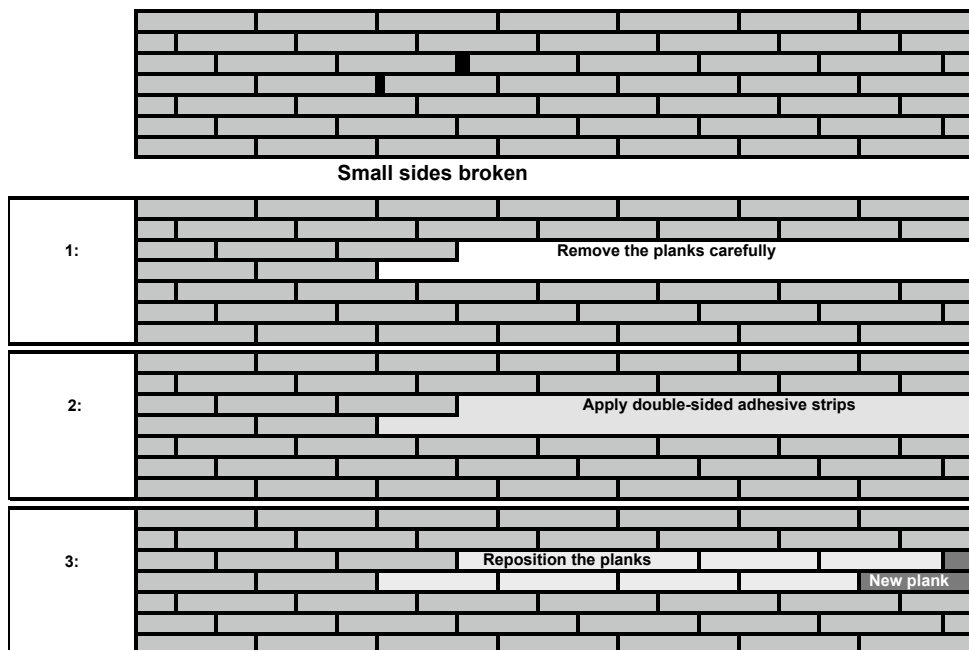

- Mark the laying direction of planks
- Unclip at an angle the side of the plank that has part A above with a straight blade
- Unclip the plank by sliding a screwdriver between the part A and B
- Unclip all planks to be replaced
- Cut and remove the double side tape
- Clean the subfloor and replace the double side tape at the place of the planks are to be replaced
- Replace the first row of planks / tiles with cut beforehand PartA of the tongue
- Then place the other blades by clipping
- Finish the lengths with new planks / new tiles



If welding is necessary, see § 3: WELD HOT p.63

### ■ 7.2 - IF ONE PLANK REQUIRES REPLACEMENT

- Define the direction of installation by screwing a screw into a blade angle to find the part B which unclip easily (or cut with a straight blade)
- Finish to unclip the plank/tile by sliding a screwdriver between the part A and B
- Cut and remove the adhesive double-face at the location of the plank/ tile to replace
- Clean the surface and put double-sided tape
- Put the new blade with cut beforehand PartA of the tongue

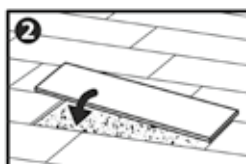

We advise you to keep a "buffer" stock of boards for possible replacement and to avoid colour differences.

### • Methodology

Hot welding requires three stages of work after laying the floor covering.

#### ■ 8.1 - CHAMFERING

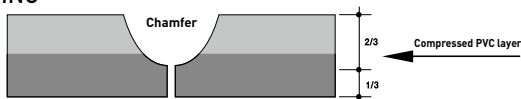

Tooling required:

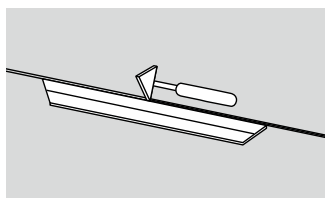

Triangular scraper and straight edge

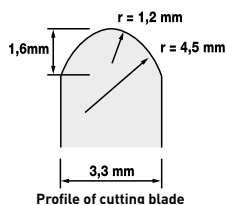

Profile of cutting blade

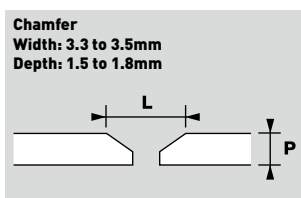

**Chamfer**  
Width: 3.3 to 3.5mm  
Depth: 1.5 to 1.8mm

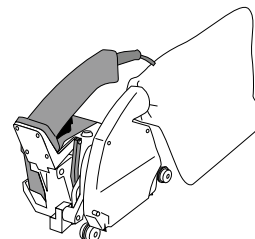

Chamfer machine

#### ■ 8.2 - Hot welding

USING A HIGH-SPEED NOZZLE

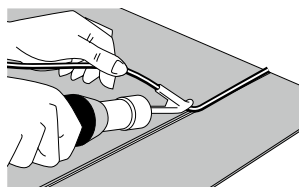

Nozzle part no. Gerflor : 0563 0001

USING A MACHINE



Use a LEISTER UNIVERSAL or UNIFLOOR welding machine with an electronically variable hot air heat source and a multi-jet nozzle with the small jet designed 2mm for this purpose.

#### ■ 8.3 - Trimming the weld seam flush

##### • Using a MOZART cutter:

1<sup>st</sup> pass: Rough trim by placing the trimmer guide under the MOZART cutter blade (fig 1)

2<sup>nd</sup> pass (The weld seam must be totally cold):

Turn the trimmer guide through 90° to one side to remove any excess weld rod seam completely (fig 2).

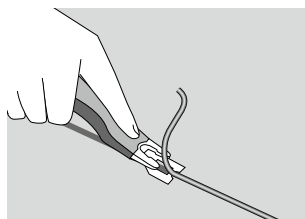

Fig. 1 - Trimmer guide under blade

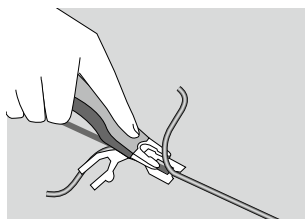

Fig. 2 - Trimmer guide at 90°

This trimming method avoids leaving hollow weld seams.

TOOLS	GERFLOR PART NO.
MOZART knife	0561 0001
Spare blades	0542 0001

### EQUIPMENT NEEDED:

Knife with straight blade / Square / Rule / Tape Measure / CORDEX /  
EXAKT Saw circular type DC170 (ROMUS ref: 93891) Screwdriver Torx T10

### 1. Incorporating an Entrance Mat

The installation of the entrance mat is to be performed after completion of the Creation Clic 70 planks.

Identify the area of the entrance mat by drawing a rectangle of 152.5 x 102.5 cm on the Creation Clic 70 planks.

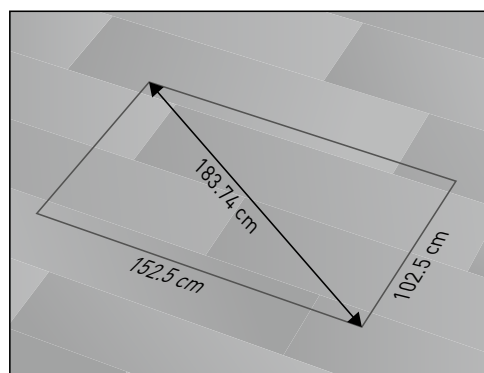

### 2. GTI Removal

Cut along the trace line on the surface of the Creation Clic 70 plank with an EXAKT DC170 saw (ROMUS ref: 93891) to a depth of 1mm less than the thickness of the Creation Clic 70 plank (eg 5mm verses 6mm for a Creation Clic 70 plank) and stopping at few centimeters from the corners.

Finish cutting the material at the corners with a straight blade knife. Clear the area of material.

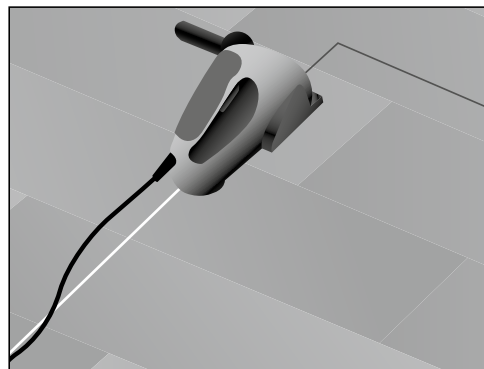

### 3. Setting the Entrance Mat Frame

#### 3.1. PLACING THE BASES

Position the 4 bases under the Creation Clic 70 leaving a clearance of 3-5 mm.

Leave a 5cm gap at each corner.

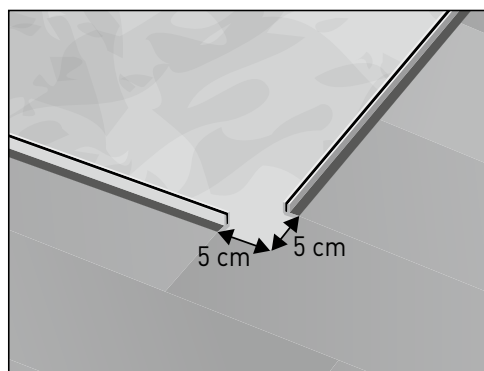
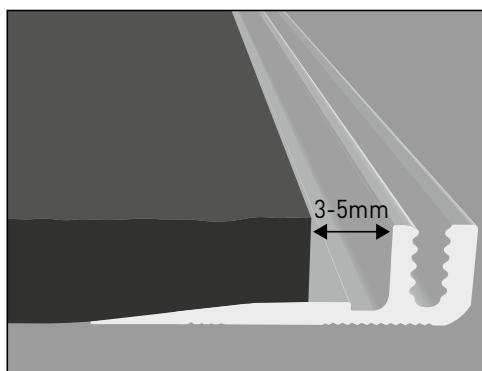

# 9

## ENTRANCE MAT INCORPORATING ROMAT GT FROM ROMUS

### ■ 3.2. INSTALLATION OF THE CORNERS

Place the 4 corners loosely in position (Do not fix).

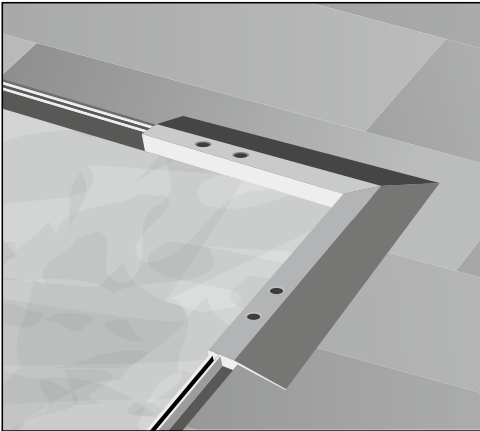

### ■ 3.3. INSTALLATION OF UPPER RAMPS

Position the 4 upper ramps.

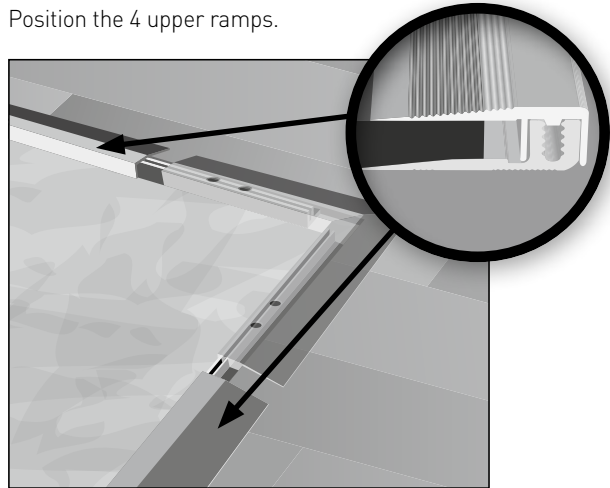

### ■ 3.4. TIGHTENING THE UPPER RAMPS

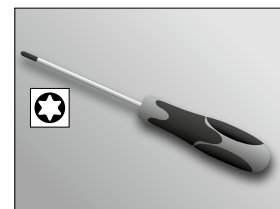
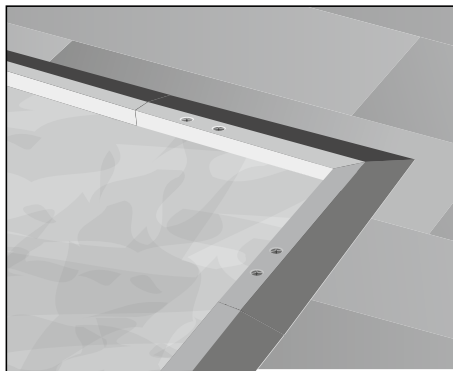
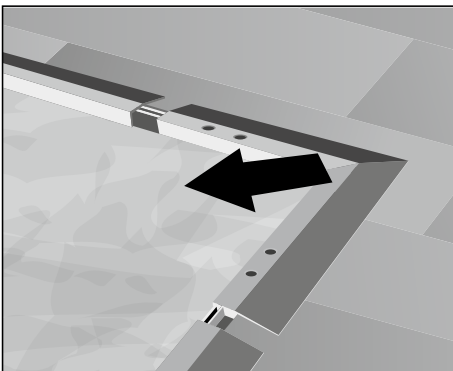

Ensure a tight fit between the 4 corners and the adjoining ramps.  
Screw ramps and corners using a Torx screwdriver (No. 10).

## 4. Setting up the entrance mat in the frame

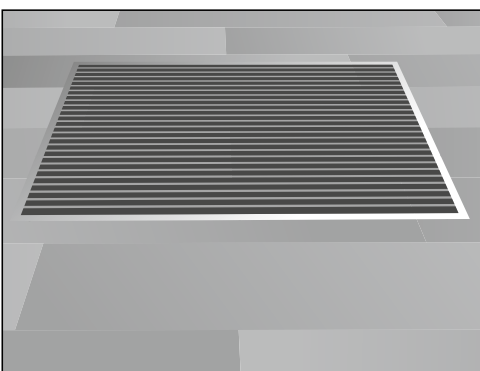

Unroll the pre-made mat into place, ensuring it is square to the area and flat to the floor.





**IRELAND:** Gerflor Ltd  
Tel: +353 (0) 42 966 1431  
Fax: +353 (0) 42 966 1759  
e-mail: gerflorirl@gerflor.com  
www.gerflor.ie

**UNITED KINGDOM:** Gerflor Ltd  
Sample service: Contractuk@gerflor.com  
Office Tel: + 44 (0) 1926 622 60  
Fax: + 44 (0) 1926 401 647  
www.gerflor.co.uk

gerflor.com

**ARCHITECTURE  
DECORATION  
SPORT  
TECHNOSPECIFIC**

RC Lyon B 726 580 152 - jpe - Printed in CEE 209 406 - 12/2016

**Gerflor.** *Don't forget* our complementary ranges!



Handrails



Wall Coverings & Protections



Entrance mats



Skirtings & Profiles

and *Be* CONNECTED!



www.gerflor.com



Committed to sustainable development

**Gerflor**<sup>®</sup>  
theflooringgroup