

SPM WALL PROTECTION AND HANDRAILS

gerflor.com



INSTALLATION PROCEDURES

NOTES

A series of horizontal dotted lines for writing notes.

CONTENTS

1 - PROTECTION RAILS AND PLATES

- 1. Tools required..... page 4
- 2. Installing IMPACT and ALINEA protection rails..... page 5
- 3. Installing CONTACT protection plates..... page 7

2 - DECOCHOC PANELS

- 1. Tools required..... page 8
- 2. Conditions for installation..... page 9
- 3. Installing DECOCHOC panel..... page 10
- 4. Installation procedures..... page 11
- 5. DECOCHOC panel maintenance..... page 19

3 - CORNER PROTECTORS

- 1. Tools required..... page 20
- 2. Installing CORNER PROTECTORS..... page 21

4 - HANDRAILS

- 1. Tools required..... page 24
- 2. Installing HANDRAILS..... page 25
- 3. Installation procedure..... page 25
- 4. Internal, external and made-to-measure angles..... page 30
- 5. Jointing HANDRAILS..... page 31
- 6. Shim..... page 32
- 7. Installing HANDRAILS on staircases..... page 32
- 8. Installing HANDRAILS with service duct kit..... page 33
- 9. Installing curved HANDRAILS..... page 34

WARNING:

Because technology is constantly evolving, it is up the user to check with our customer support department that this document is the applicable version before beginning any installation work. The installation contractors must comply with regulations applicable on the date the work order is signed.

The material should be examined before installing to avoid any defects from showing up in the final result. Once the material is installed, reworking costs cannot be charged to us.

This document is applicable on 01/11/2010 and may be updated without prior notice.

— PROTECTION RAILS AND PLATES

1. TOOLS REQUIRED

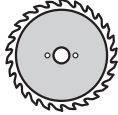

- **Circular saw with fine-toothed carbide blade for aluminium and PVC**
E.g. JANSER-type KSS 300, Part No. 240 996 000



- **Rubber mallet**
E.g. JANSER-type Part No. 262 467 000



- **Measuring tape and pencil**
E.g. JANSER-type Part No. 262 481 000
or



- **Laser**
E.g. JANSER-type LL120 Part No. 270 580 000



- **Level & measuring device**
E.g. JANSER-type NIV'O Part No. 110 145 000

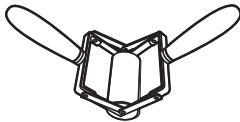

- **Double-handed pressure roller**
SPM Part No. OUTRM002



- **Drill and screwdriver**
E.g. JANSER Part No. 575 300 000

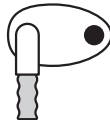

- **Suction cup**
E.g. JANSER Part No. 570 930 000

2. INSTALLING IMPACT AND ALINEA PROTECTION RAILS

The SPM protection rails IMPACT and ALINEA models, are wall protections in the form of a PVC profile to attach either on brackets or an aluminium rail. The product provides continuous protection all along the wall's surface by the use of internal and external angle pieces. Its appearance is enhanced by the use of end-pieces.

These protection rails must be screwed to the wall. The table below shows the installation techniques to be used for the various wall surfaces found in the building industry.

TYPE OF WALL	INSTALLATION PROCEDURE
Walls with wooden studs	Woodscrews, 5 x 40 mm
Metallic structures	Self-tapping screws, 5 x 40 mm
Plasterboard (single skin), hollow brick, hollow breeze block	Self-tapping screw-plugs
Plasterboard (double skin)	Self-tapping screw-plugs
Concrete walls	FISCHER-type plugs, 6 mm diameter, for 5 x 40 mm screws
Solid brick wall, old walls	FISCHER-type plugs, 8 mm diameter, for 5 x 40 mm screws
Hollow plaster tiles, cellular concrete	FISCHER-type plugs, 8 mm diameter, for 5 x 40 mm screws

2.1 IMPACT AND ALINEA PROTECTION RAIL INSTALLATION PROCEDURE

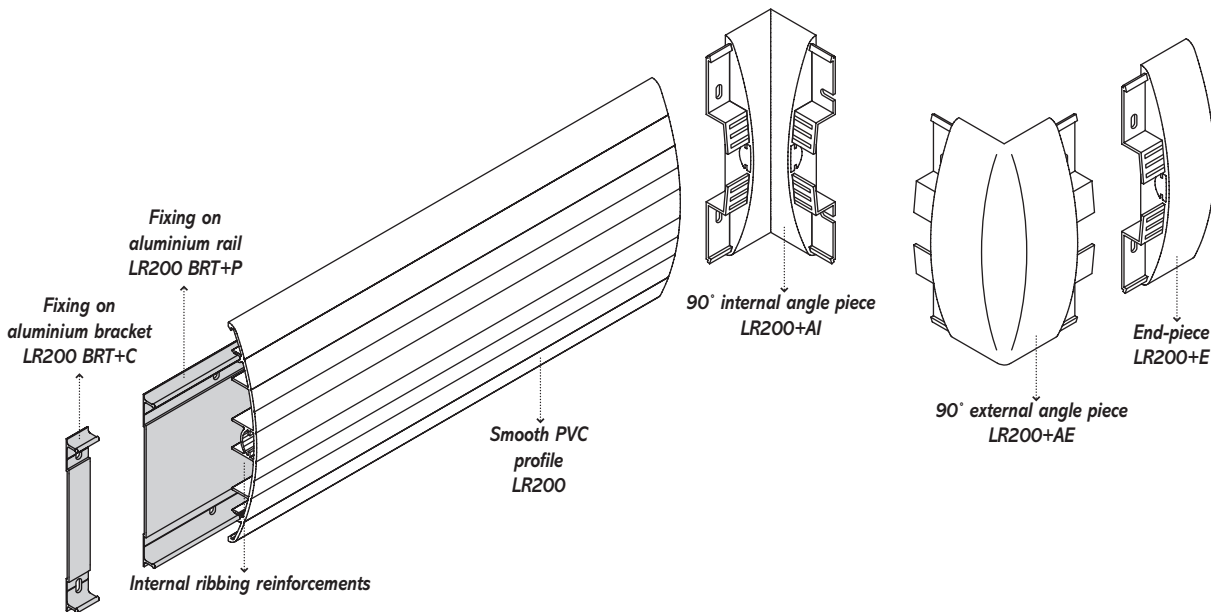

■ Where profiles have to be cut to length in advance, the table below shows the allowances to be subtracted from the wall dimensions for the cutting-out of the PVC profile.

■ The length of the aluminium rail is then calculated by subtracting 40 mm from the length of the PVC section.

IMPACT/ALINEA PROTECTION RAILS	END-PIECE	EXTERNAL ANGLE PIECE	INTERNAL ANGLE PIECE
IMPACT/ALINEA 200	50 mm	25 mm	65 mm
IMPACT/ALINEA 120	49 mm	20 mm	65 mm
IMPACT 60	45 mm	20 mm	65 mm

	LOWER WALL PROTECTION	UPPER WALL PROTECTION
Protected wall height (at protection rail centre-line)	200 mm above floor level	800 mm from floor level
Use pencil or laser to draw upper and lower drilling centre-lines along wall		
IMPACT/ALINEA 200	360 and 240 mm	960 and 840 mm
IMPACT/ALINEA 120	290 and 230 mm	890 and 830 mm
IMPACT 60	239,5 and 220,5 mm	839,5 and 820,5 mm

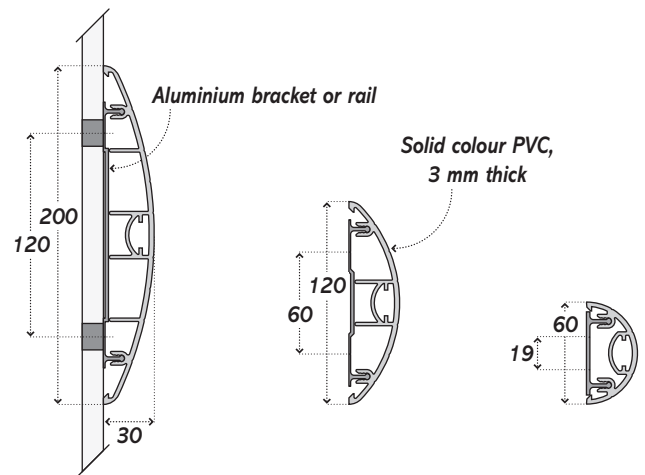

■ Place the end-pieces and any internal/external angle pieces over these lines, check that they are vertical with respect to the floor, and mark their pre-drilled hole positions on the wall (fig.1).

■ Drill the wall, fit the screw-plugs and then mount the end-pieces and angle pieces on the wall (fig.1).

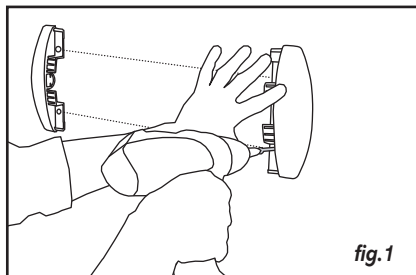

fig.1

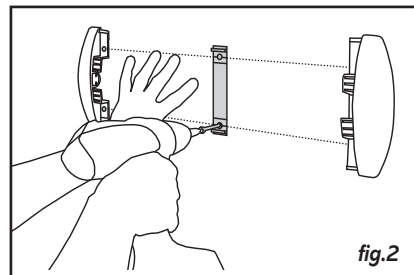

fig.2

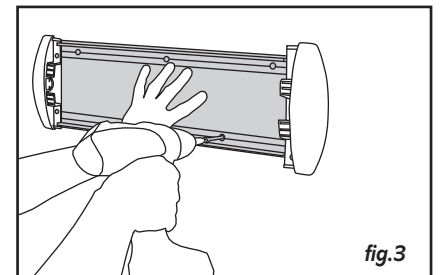

fig.3

OPTION 1: For an installation on aluminium brackets (fig.2)

OPTION 2: For an installation on aluminium rails (fig.3)

■ Place the aluminium brackets over the centre-lines and space the brackets no more than 750 mm apart. The end pieces double as the first bracket. Check that they are vertical with respect to the floor and then mark their pre-drilled hole positions on the wall. Drill the wall, fit the screw-plugs and then mount all the aluminium brackets on the wall.

■ Measure the length between each end-piece or angle-piece and then cut the rail to length using a circular saw. Drill through the rail along the grooved lines, starting at 20 mm from one end and then spacing the holes no more than 750 mm apart. Place the rail over the centre lines on the wall and mark each hole on the wall. Drill the wall, fit the screw-plugs and then mount the rail on the wall.

⚠ Where the wall surface is uneven, we recommend using fixing brackets at the start, middle and end of the uneven patch in order to force the profile strip to follow the wall's surface and thus avoid excessively large gaps.

⚠ CAUTION: The lengths of the aluminium rail and its PVC profile are not the same (fig.4).

FOR BOTH ATTACHMENT OPTIONS (BRACKET OR RAIL):

- Measure the distance from end-piece to end-piece, or angle piece to angle piece, and then cut the PVC profile strip to length using a circular saw.
- When fitting ALINEA protection rails, cut the contrast strip to length whilst it is snap-fitted to the main PVC profile, and then fit the complete assembly onto the aluminium brackets or rail.
- Now mount the PVC profile onto the brackets or rail by striking it firmly, using a rubber mallet where necessary. Finally, check that the PVC profile is properly snap-fitted over all the brackets or along the full length of the rail (fig.5 and fig.6).

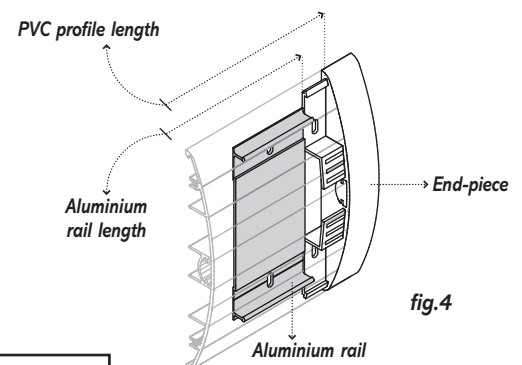

fig.4

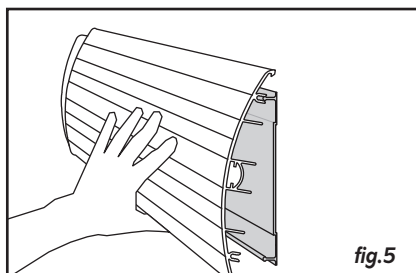

fig.5

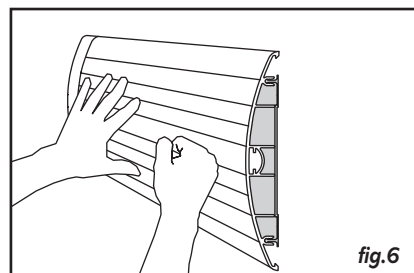
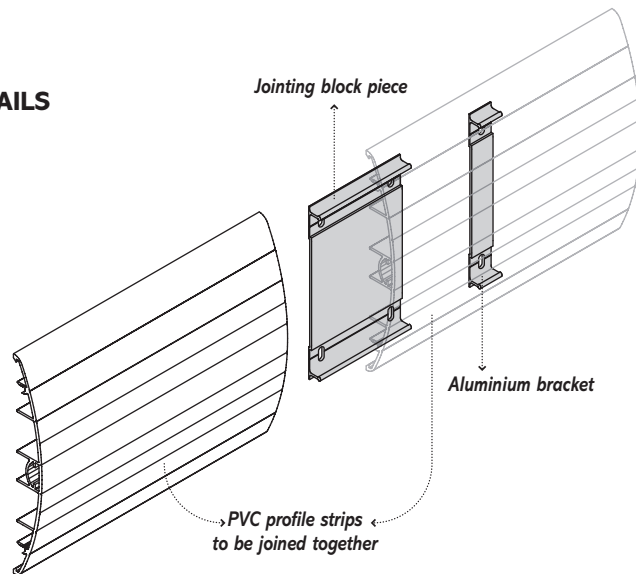

fig.6

2.2 JOINTING IMPACT AND ALINEA PROTECTION RAILS

- For wall runs over 4 000 mm long, PVC protection rails mounted on brackets may be joined together using a piece of aluminium 100 mm long to provide a smooth joint and hold the protection rail in place.
- These pre-drilled pieces are attached to the wall at four mounting points.



3. INSTALLING CONTACT PROTECTION PLATES

SPM CONTACT protection plates are wall protections in the form of 2 to 2.5 mm thick PVC extruded profiles.

These protection plates should be attached directly to walls using SPM mastic glue.

Strips of adhesive foam are laid along the edges (and in the centre for the CONTACT 350) in order to hold the protection plate in place temporarily while the glue dries (tack time). These adhesive foam strips alone do not provide permanent support.

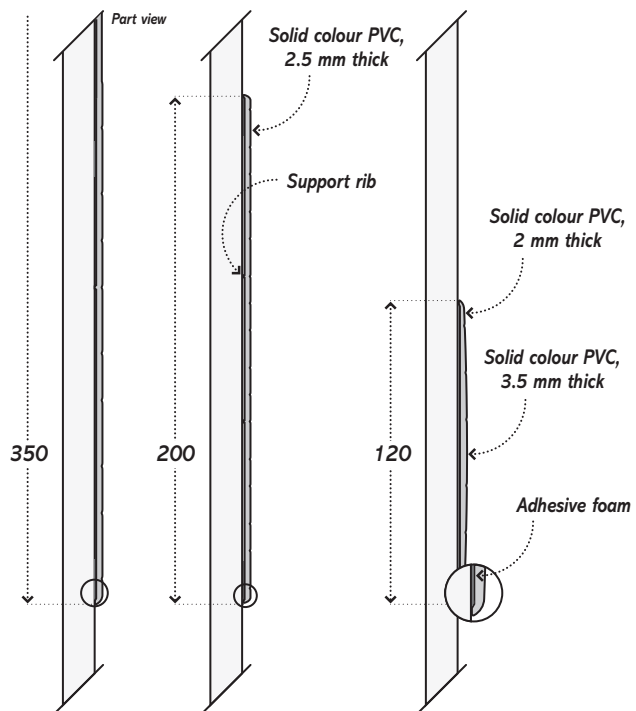

3.1 CONTACT PROTECTION PLATES INSTALLATION PROCEDURE

- Apply the SPM mastic glue to the surface of the PVC profile as shown in the drawing opposite.
- Mark the height of the protection rail on the wall using a spirit level and a pencil (or a laser).
- Remove the protective films from the adhesive foam strips.
- Place the protection plate against the wall, taking care to follow the drawn lines (once in position on the wall, the protection plate cannot be moved).
- Press down hard (with a roller) all over the outer surface of the PVC profile.
- Clean off any excess glue with a rag and hot water.

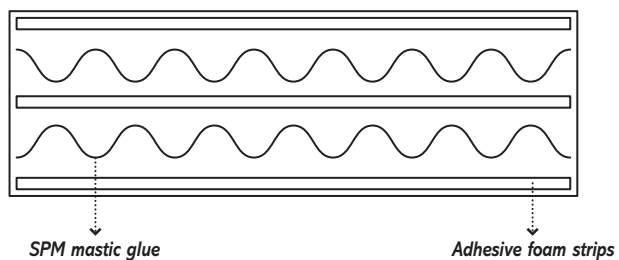

— DECOCHOC PANELS

2

1. TOOLS REQUIRED



- **Tape measure and pencil**
E.g. JANSER Part No. 262 481 000



- **Safety knife with large hooked blade**
E.g. JANSER Part Nos. 262 040 000 and 262 036 500



- **Wood/PVC plane**
E.g. JANSER-type lino Part No. 262 413 000

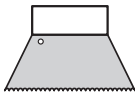

- **Stainless steel spreader with notched profile, type A2**
SPM Part No. OUTCC001 or OUTCC002

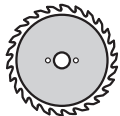

- **Circular saw with fine-toothed carbide blade for aluminium/PVC for straight cuts and ripping**
E.g. JANSER-type KSS 300 Part No. 240 996 000



- **Humidity tester**
E.g. JANSER Part No. 110 270 000

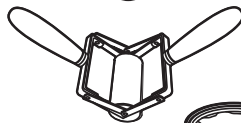

- **Double-handled pressure roller**
SPM Part No. OUTRMOO2



- **SPM Acrylic glue**



- **Hot-air welding gun, LEISTER TRIAC S, 230V, 1550W with ULTRA speed welding nozzle for 5 mm filler**
E.g. JANSER Part Nos. 224 818 000 and 224 800 007

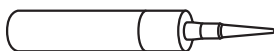

- **SPM Silicon jointing compound**



- **Quarter moon knife/spatula knife**
E.g. JANSER Part No. 262 621 900

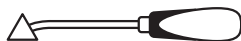

- **Triangular scraper**
E.g. JANSER Part No. 262 613 000

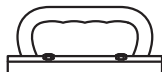

- **Seam plane with 2 blades**
E.g. JANSER Part No. 262 626 000

- **Bell saw or precision saw**
E.g. JANSER Part No. 270 700 000

- **PVC spatula**
E.g. JANSER Part No. 464 076 000

- **Retaining strap**
E.g. JANSER Part No. 851 021 000

- **Solvents, non-residue (grease or dry) e.g.:**
Ethanol / Isopropyl alcohol, heptane, TAGOX graffiti remover

- **Tack rags**

2. CONDITIONS FOR INSTALLATION

2

■ 2.1 BEFORE FITTING

- Check the humidity levels of the surface to be glued at several points using a humidity tester. Humidity levels must not exceed 25%.
- Check that the surface of the wall is not greasy or loose and that there are no large holes. Holes wider than 50 mm or deeper than 10 mm must be filled in with plaster before the installation.
- DECOCHOC panels must be at the same temperature as the premises in which they are to be installed (for at least 24 hours) in order to prevent distortion.
- Any tests of heating or air conditioning systems for the premises must be carried out before fitting the panels.
- If the panels will be exposed to temperature changes in excess of 10° C (e.g., behind a bay window), expansion joints must be provided.
- If the installation is carried out at a temperature significantly different from 20°C (unheated premises in winter), bear in mind the variations shown in the table below when installing.

■ 2.2 TABLE OF DECOCHOC PANEL DIMENSIONAL VARIATIONS

TEMP °C	VARIATION (IN MM) FOR EACH METRE OF LENGTH	REMARKS
15	-1	Minimum temperature
20 (ideal temperature)	0	Ideal temperature
25	+1	Permissible temperature
30	+2	Maximum temperature

If the work has to be performed in very hot premises, and before the air-conditioning system comes into service, which will cause the DECOCHOC panels to contract, we advise using more panels of a shorter length in order to spread the contraction over a larger number of joints.

3. INSTALLING DECOCHOC PANEL

DECOCHOC panels may be attached using glues or adhesive films, depending on the type of surface needing protection. The table below shows the assembly procedures to be used for the main types of materials used in buildings.

For each procedure, it is important to press down on the bonding surfaces with a minimum pressure of 1 kg/cm² (14 psi).

TYPE OF WALL	INSTALLATION PROCEDURE
Plaster, plaster-board (1)	Acrylic glue
Brick	Acrylic glue
Wood	Acrylic glue
Tiles, glazed tiles (2)	Acrylic glue
Rough surfaces such as glass fibre, wallpaper, rough-cast paint (3)	Acrylic glue
PVC (4)	Acrylic glue, double-sided adhesive transfer film, SPM mastic glue
Sheet metal	Acrylic glue (metal protected by anti-rust paint), double-sided adhesive transfer film, SPM mastic glue
Laminates (5)	Acrylic glue, double sided adhesive transfer film, SPM mastic glue
Gloss painted surfaces (6)	Acrylic glue, double sided adhesive transfer film, SPM mastic glue
Glass, Perspex	Acrylic glue, double sided adhesive transfer film, SPM mastic glue

(1) With bare plaster or BA13 plasterboard, apply a UZIN PE360 type primer before the glue.

(2) When installing onto glazed tiles, apply a primer suited to this surface and protect the film of glue with silicone jointing compound all round the edge of the panel.

(3) For all rough cladding surfaces, apply sufficient glue to the surface to cover all protrusions. Be ready to use a somewhat greater quantity of glue. Check beforehand that the glass fibre (or wall paper) is adhering properly; if not, it will be necessary to

remove the glass fibre (or wall paper).

(4) When fitting over an existing PVC panel, check that the original panel is adhering sufficiently and can take the extra weight.

(5) When using acrylic glue, it is advisable to roughen the surface to be glued in order to improve the grip of the glue.

(6) Check that the paint is thoroughly dry.

3.1 IMPORTANT INFORMATION ABOUT SPM ACRYLIC GLUE

- SPM acrylic glue is solvent-free and odourless.
- This glue has a long working time, sticks to absorbent and non-absorbent surfaces and has a high degree of tack.
- SPM acrylic glue has an open time of 20 – 30 minutes at temperatures between 18 and 25°C, with a relative humidity of 75%. The open time varies as a function of the air temperature and humidity, and the porosity of the surface.
- Once gluing is complete, the glued panel can be moved a few millimetres. It is not possible to adjust the panel's position once it has been pressed down.
- Fresh glue streaks can be removed with warm water. Dried glue can be removed using a PVC spatula.
- SPM acrylic glue may be stored for 12 months but must be protected from frost (it is irreversibly damaged at -2°C).

3.2 DAMP ENVIRONMENTS

In particularly damp places, where the relative humidity exceeds 90%, the open time of the acrylic glue may be excessively long, or it may not dry at all. In such cases, one should use a modified silicon (MS) polymer glue such as SPM's universal mastic glue. This gives adhesion on most surfaces and works very well in damp environments.

4. INSTALLATION PROCEDURES

2

■ 4.1 CUTTING OUT AND ADJUSTING THE DECOCHOC PANELS

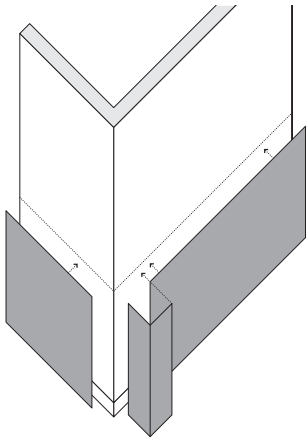

- Measure each section of wall and then cut the DECOCHOC panels to the heights and lengths required.
- Use a hooked blade or a circular saw to cut the panels to shape.
- Use numbers to mark the location of the panels on the sections of walls.
- Place the panels against their respective wall sections and check for alignment against mouldings, skirting and floors (fig.1).

- To align properly, place the panel against the wall and press it against the floor (or skirting). Then set the panel horizontally with the aid of a spirit level and mark a line on the panel parallel with the floor (or skirting). Cut the panel along the line. Repeat this procedure for the vertical alignment (fig.2 and 3).
- Adjusting the alignment (or re-cutting, where necessary) should be done with a hooked knife and a plane.
- Once the panel's alignment is complete, place each panel against its respective wall section and use a pencil to draw the limits of the area to be glued on the wall (5 mm inside the edges of the panel).

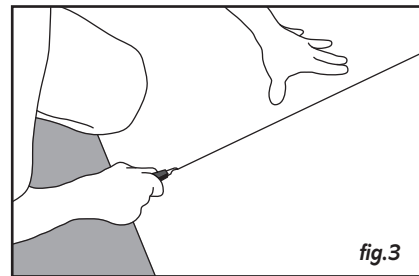
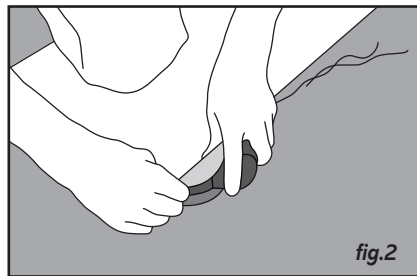
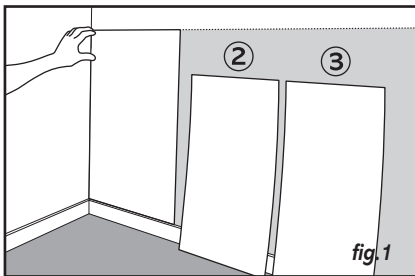

Cut-outs for wall switches or mains sockets may be made using a bell saw or precision saw, e.g.: Janser 270 700 000.

■ 4.2 APPLYING THE GLUE AND FIXING THE DECOCHOC PANELS

- The glue should be applied with a stainless steel spreader with notched profile, type A2.
- Spread the glue over the entire wall surface marked out earlier (fig.1). Applying it to the wall is easier than applying it to the panel for onsite environments and avoids getting dust on the adhesive during the glue's open-time phase.
- Apply the glue to a thickness of 1 to 2 mm over the wall's surface, using a quantity of 250 – 300 g/m².
- Once the surface is completely covered, allow 20 to 30 minutes open time before fixing the panel.

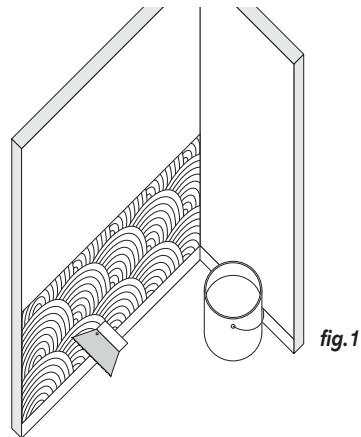

fig.1

- Check the glue's open time by placing a fingertip against the glued surface. If filaments appear when the finger is withdrawn, the open time is satisfactory (fig.2).
- It is important to clean all of the panel's smooth surface (glue side) using a tack rag before each gluing session (fig.3).
- Set the DECOCHOC panel in place, being sure to respect the wall clearances decided earlier on each side.

- Press down over the entire surface of the panel, using a roller, and apply a pressure of 1 kg/cm² (fig.4).
- Using a rag dampened with warm water, clean off any excess glue.
- Finish off the top of the panel with a plane in order to remove the sharp edge and leave a slight chamfer.
- Finally, clean the surface of the DECOCHOC panel with a degreasing solvent.

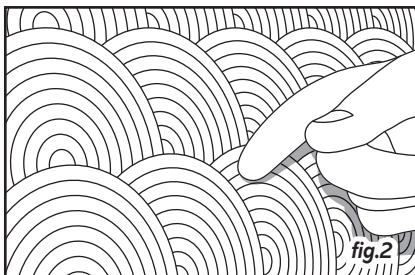

fig.2

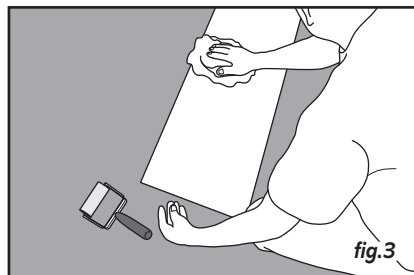

fig.3

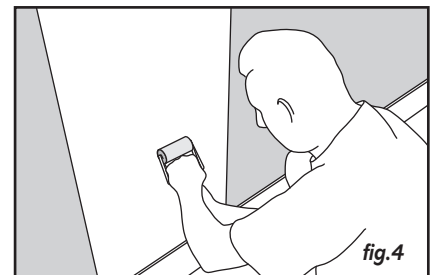

fig.4

Where the length of the wall is greater than 3 metres, it will be necessary to fit several DECOCHOC panels side by side. These panels must be fitted one after the other. The first panel must be adjusted and fixed to the wall before the second panel can be properly aligned with the first (especially when jointing) (fig.5).

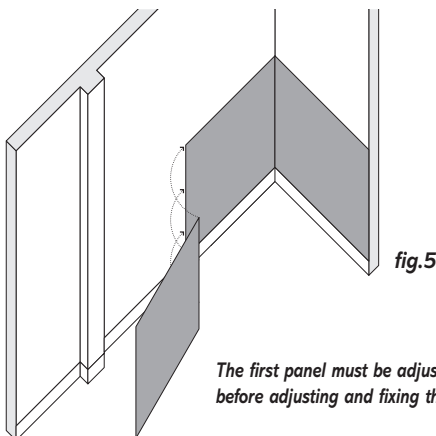
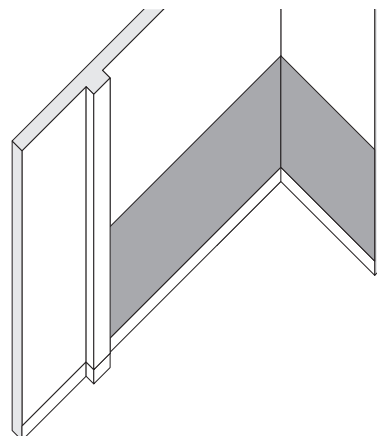

fig.5

The first panel must be adjusted and fixed to the wall before adjusting and fixing the next one.



- The joints between panels can be made:
- with an SPM hot-melt seal in a matching colour
 - or with an SPM silicon seal in a matching colour
 - or by abutting the panels

- Leave a 2 mm gap between panels for hot-melt or silicon joints. Once the panels have been installed (after leaving them to acclimatise at room temperature for 24 hours), the joints will absorb any expansion due to normal temperature fluctuation (+ or - 5°C).
- For extensive temperature fluctuations, refer to the dimensional variation table on page 9 to evaluate expansion and multiply the number of joints along the wall accordingly to absorb expansion.

- If the panels are abutted, leave necessary expansion gaps in the least visible areas (in corners, along door and window frames) according to the expansion evaluated the dimensional variation table on page 9.
- As a general rule, leave a gap of 1 mm between panels and fixed elements such as millwork, piping, wall sockets, handrail brackets, etc.

■ 4.3 LAYING HOT-MELT JOINTS

Hot-melt joints are used to provide a good seal when assembling two DECOCHOC panels together, or any DECOCHOC panel against a PVC skirting edge.

- Check that there is a 2 mm gap between the panels.
- Use a chamfering tool to cut a chamfer between the two panels (fig.1).
- Cut a length of hot-melt filler, adding 100 mm to the working length.
- Check that the melt-gun nozzle is clean.
- Set the gun temperature to setting 5 (for a 1600W gun). Let the gun warm up for 2 minutes until it reaches its working temperature.
- Feed the filler compound into the nozzle and begin to lay the joint.
- Lay the joint from top to bottom, maintaining pressure on the start point with a finger (fig.2).
- Work slowly downwards along the length of the joint, taking care to ensure good adhesion of the joint and the panel without burning the panel. The speed should be about 20 mm per second.
- At the end of the joint, use a knife to cut off any excess filler but keep pressure on the end of the joint for about 15 seconds (fig.3).
- Reset the gun to the 0 setting until it has cooled down properly and then switch the gun off.
- Clean the nozzle using a brass wire brush.

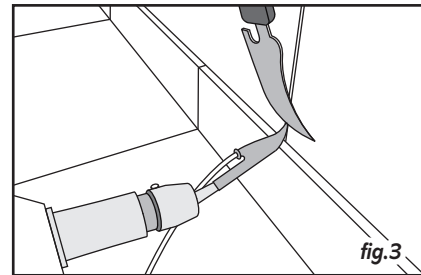
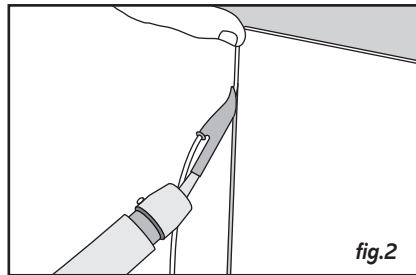
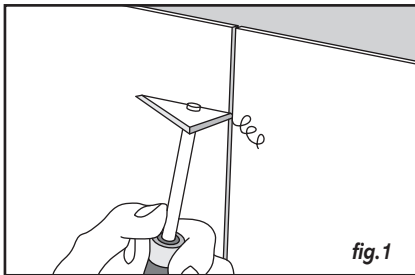

- Cut back any excess filler above the joint using a knife (fig.4).
- Let the joint cool completely for about ten minutes.
- Finally, use a seam plane to remove any excess filler compound (fig.5).

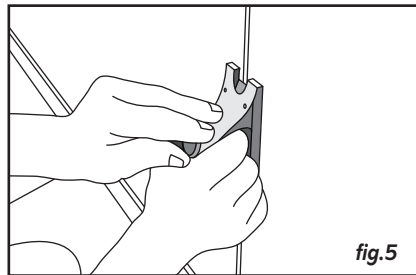
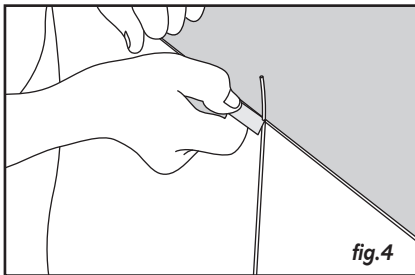

■ 4.4 LAYING SILICONE JOINTS

Silicon joints are used to provide a good seal between DECOCHOC panels and frames, skirting or between the panels themselves at corners.

- Check that there is a 2 mm gap between the panels and the fixed building elements.
- Apply a strip of adhesive tape to protect each side of the joint (fig.1).
- Use a silicon jointing gun to lay a strip of silicon along the length of the joint (fig.2).
- Spread the silicon joint using a fingertip (fig.3).
- Remove the protective strips of adhesive tape.

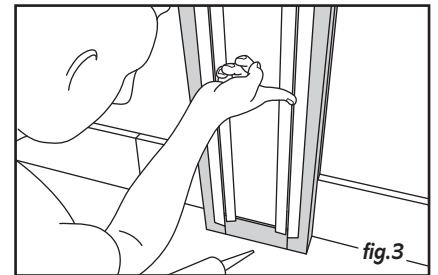
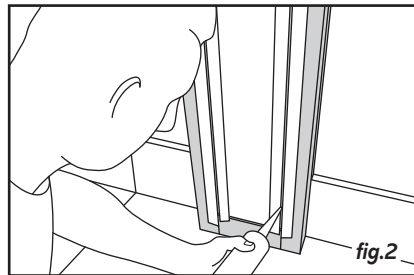
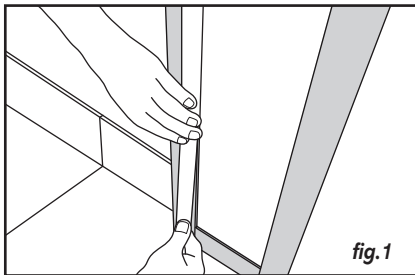

■ 4.5 INSTALLING DECOCHOC PANELS ON ROUND PILLARS

Fitting protection to round pillars may be achieved with pre-shaped DECOCHOC panels, curved by hot-forming to fit the dimensions of the pillar. Each pillar is protected by two hot-formed panels (i.e., in two halves).

DECOCHOC products need hot-forming for pillar diameters up to 800 mm. Beyond 800 mm, the panels are sufficiently flexible to be fitted to curved surfaces.

DECOCHOC hot-formed panels should be made 10 mm oversize in both width and height to allow for adjustment when fitting.

- Fit the first hot-formed panel using the correct procedure for fitting DECOCHOC panels (fig.1).
- Given the rounded shape, two coats of glue will be necessary to attach the hot-formed panels to the pillar. Outline the areas to be glued and then apply the glue to both the panel and the pillar.
- Then fit the second panel, leaving gaps of 2 mm between the two panels on each side (fig.2 and fig.3).
- Once the two panels are fitted, seal the panels with a hot-melt joint on either side of the pillar (fig.4).
- If the fitting of the two halves is difficult around the edges, especially where the pillar's curves are irregular, we recommend gluing them down and then strapping down the two half panels at several points for the entire drying time of the glue (at least 24 hours).

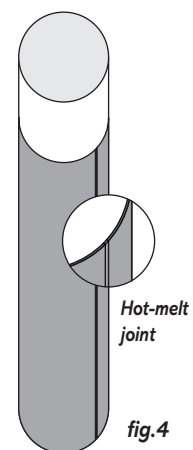
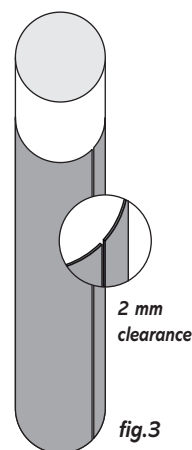
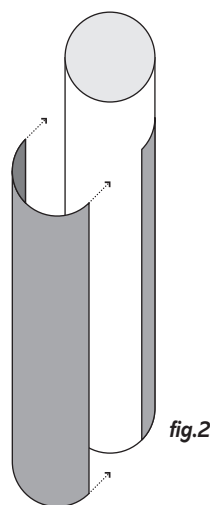
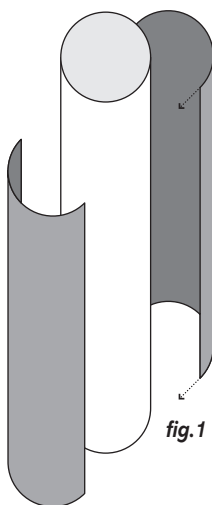

4.6 INSTALLING DECOCHOC WITH BENDS FOR ANGLES

Where DECOCHOC panels are to be fitted in operating theatres or clean rooms, it is essential to get a good seal between the wall panels themselves and the PVC flooring. In order to achieve this level of seal, we propose bends in internal or external angles that fit to DECOCHOC panels with a hot-melt joint to ensure complete sealing within the room and much easier cleaning.

- When fitting DECOCHOC panels with bends for angles, first fit all the internal and external angles within the room before fitting the flat panels (fig.1).
- Fit the bends for angles and the flat panels using the correct fitting procedures.

- Leave a gap of 2 mm between each panel for the laying of a hot melt joint (fig.2).
- Lastly, lay the hot-melt joints using the correct procedure - See paragraph 4.3 on page 13.

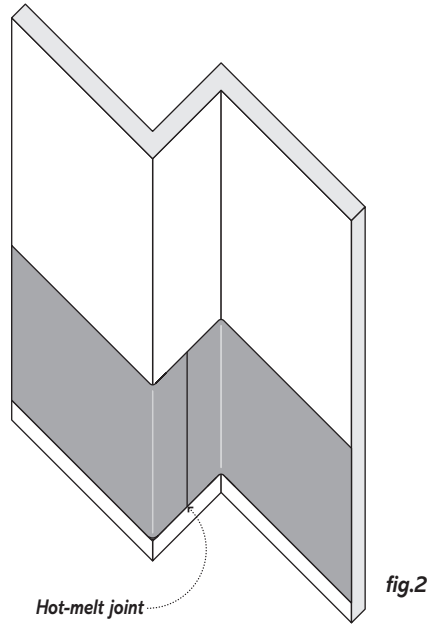
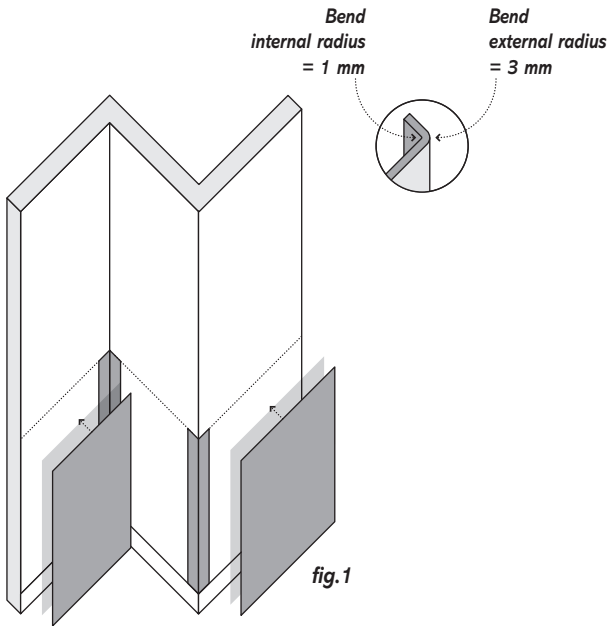

4.7 FITTING DECOCHOC PANELS TO DOORS

4.7.1 PROTECTING DOOR FACES

- Remove the door from the doorway and lay it on trestles.
- Remove the handle and the lock fixing plate.
- Use a drill with a hole-cutting saw to cut out the panel where the handle and lock pass through.
- Glue down the panel(s) to the faces of the door.
- Replace the handle and the lock fixing plate.

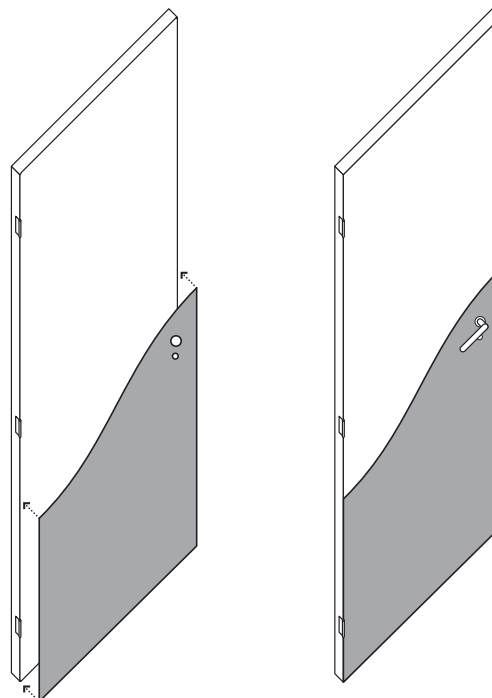
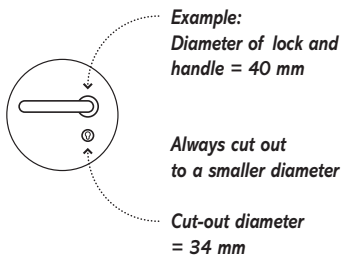

4.7.2 PROTECTING DOOR FACES AND EDGES

- Remove the door from the doorway and lay it on trestles.
 - Remove the handle and the lock fixing plate.
 - Use a drill with a hole-cutting saw to cut out the panel where the handle and lock pass through.
 - Remove any door hinges that would obstruct the relieving.
 - Use router to relieve the door by 2 mm on the right and left-hand edges (fig.1).
 - Cut out the panels where the hinges will go.
 - Glue one U-shaped panel to one side of the door (fig.2)
 - Then glue the other U-shaped panel to the other side, being sure to leave a gap of 2 mm between the two panels (plane them back or cut them to size if necessary) (fig.3).
 - Replace the door hinges.
 - Then lay a hot-melt joint along both edges of the door (fig.4).
- see paragraph 4.3 page 13.

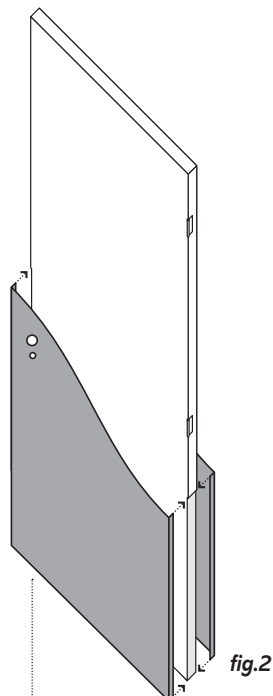
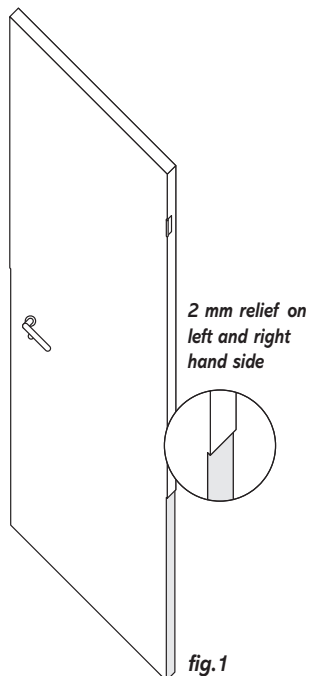
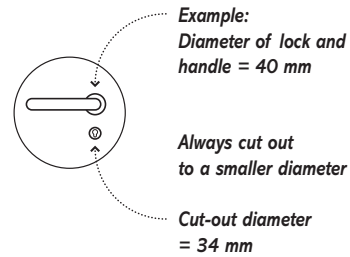

There must be no gap between the panels and the door.
Check the relief by positioning the U-shaped panels on the door.

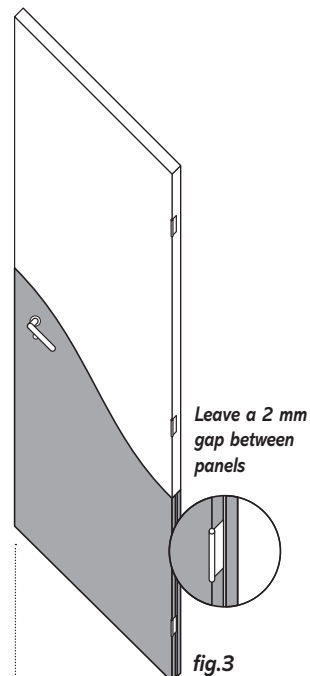

With the hinge removed, cut out the panel to leave its emplacement accessible.

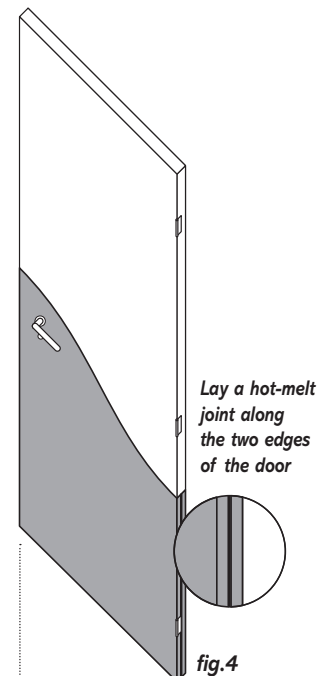

Applying hot-melt joints along the centreline of door edges makes the panel much more resistant to being torn off and improves its water tightness.

4.7.3 PROTECTING FULL DOOR

• WITH HOT-MELT JOINTS ALONG DOOR EDGES

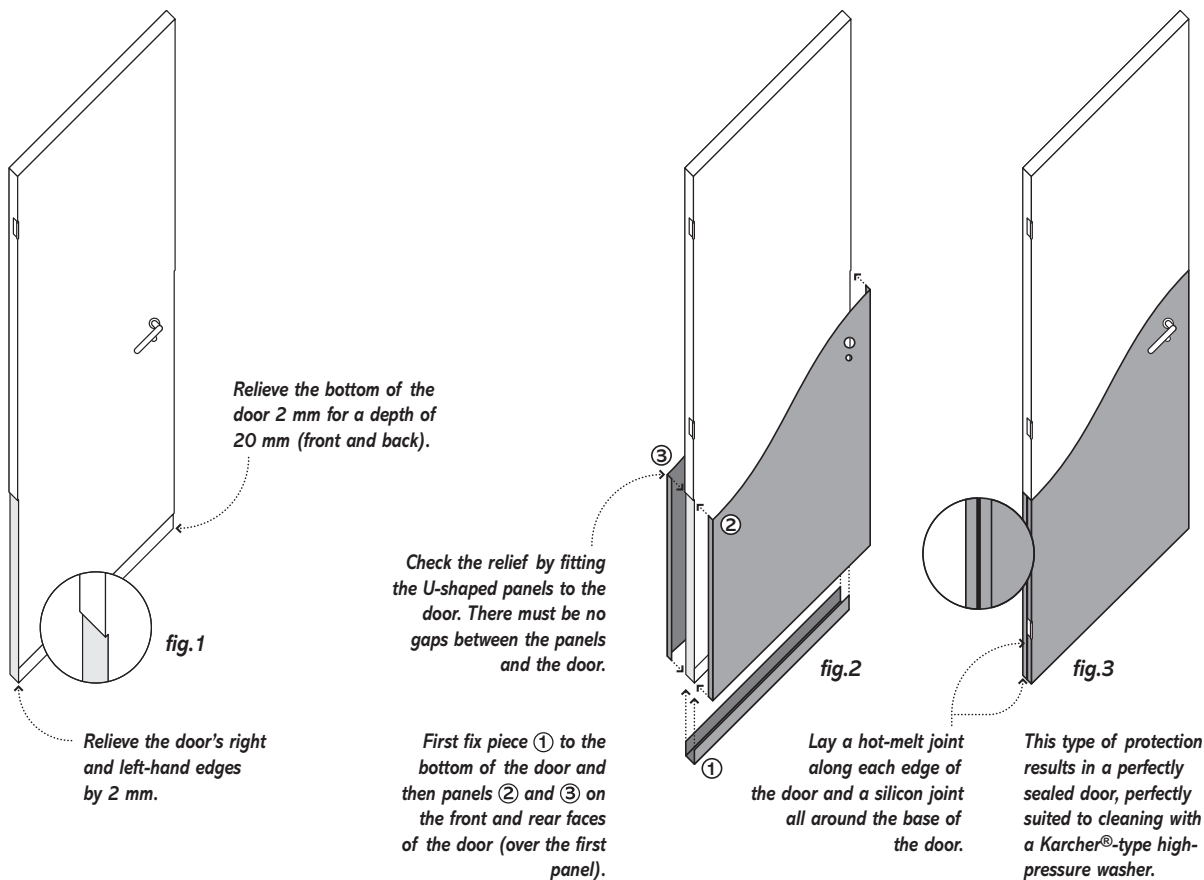

• WITH SILICON JOINTS ON DOOR ANGLES

This type of protection results in a perfectly sealed door, perfectly suited to cleaning with a Karcher®-type high-pressure washer.

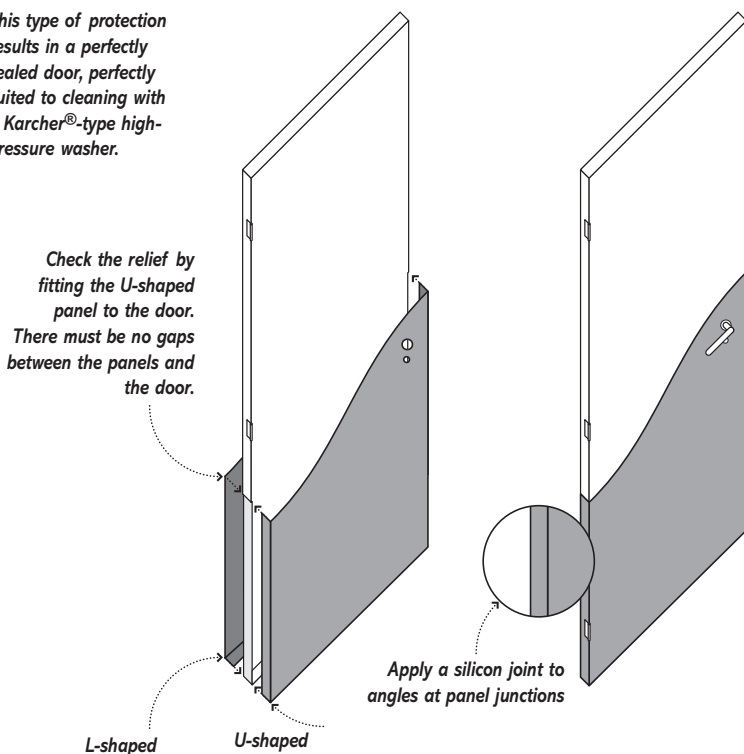

• OTHER SOLUTIONS (WITHOUT BENDS)

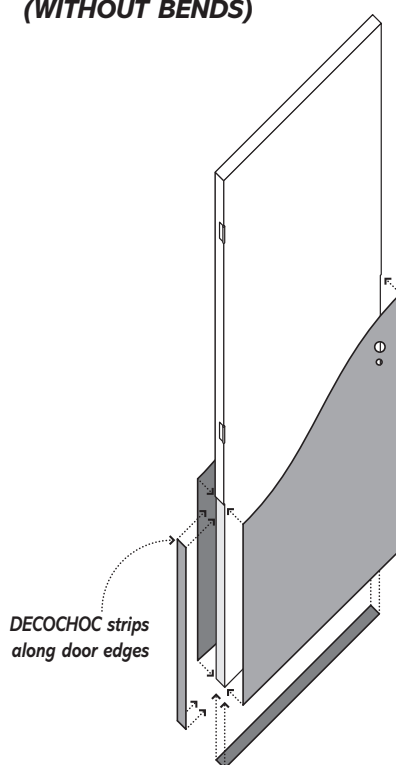

■ 4.8 FITTING DECOCHOC TO DOORFRAMES

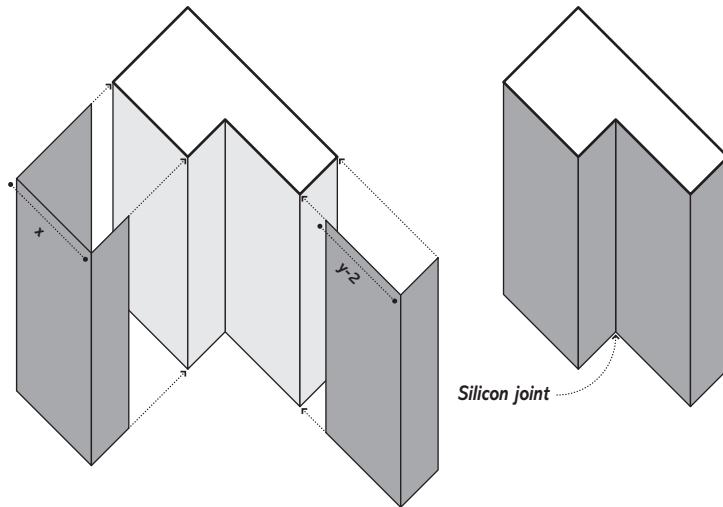

Fitting protection for doorframes may be achieved with DECOCHOC L or U-shaped panels. Glue the panels and lay a silicon joint along the corner of the doorframe - See paragraph 4.4 on page 14.

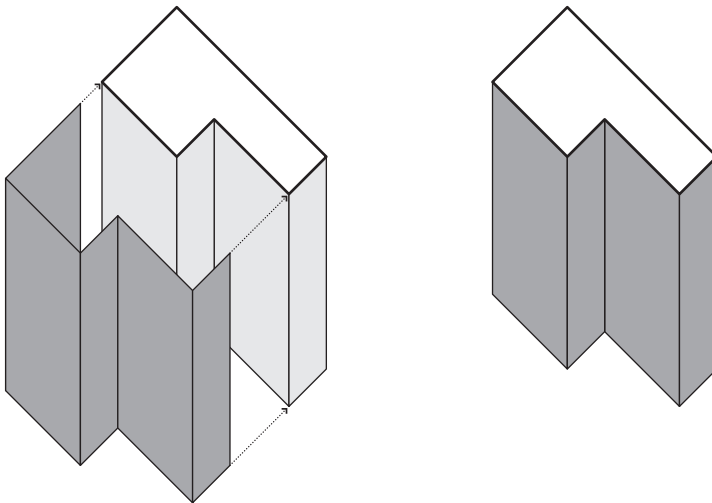

Fitting protection over the doorframes may also be achieved with a single hot-formed DECOCHOC panel made to measure for the size of the doorframe.

5. DECOCHOC PANEL MAINTENANCE

DECOCHOC panel has been tested for its resistance to the main types of cleaning materials, disinfectants and antiseptic products used by public bodies and healthcare establishments.

Amongst others, the products below have been tested and proved to cause no damage to DECOCHOC panel:

DETERGENTS	<ul style="list-style-type: none"> ■ SURFANIOS ■ DETERGANIOS ■ UNIT PLUS
DETERGENT DISINFECTANTS	<ul style="list-style-type: none"> ■ DS5001 ■ DIVOSAN S4
DESCALERS	<ul style="list-style-type: none"> ■ TASKI CALCACID
PAINT STRIPPERS	<ul style="list-style-type: none"> ■ TASKI radical ■ SUMA D9.7
DEGREASER DISINFECTANTS	<ul style="list-style-type: none"> ■ DDM
OTHERS	<ul style="list-style-type: none"> ■ 70% surgical alcohol ■ Household bleach ■ Eosin ■ Bétadine ■ Ammonia

■ For cleaning DECOCHOC panel, we recommend the following products:

- Ammonia
- Ethanol
- Isopropyl alcohol
- Heptane

■ To remove traces of ink or adhesives, we recommend using the product below:

British Nova by CLEENOL GROUP LTD, Beaumont Road, Banbury, Oxfordshire, OX16 1RB . T: 01295 251721 . F: 01295 269561

■ IT IS ESSENTIAL TO USE SOLVENTS THAT LEAVE NO RESIDUE, EITHER GREASY OR DRY.

In all cases, test the product first on a scrap piece of panel. Reactions will differ depending on the colour of the panels and the solvents used.

■ SOLVENTS NOT TO BE USED



- White spirit
- Paint thinners
- Petrol

— CORNER PROTECTORS

1. TOOLS REQUIRED

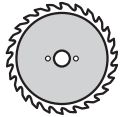

- **Circular saw with fine-toothed carbide blade for aluminium and PVC**
E.g. JANSER-type KSS 300, Part No. 240 996 000



- **Measuring tape and pencil**
E.g. JANSER Part No. 262 481 000



- **Level & measuring device**
E.g. JANSER-type NIV'O Part No. 110 145 000



- **Drill and screwdriver**
E.g. JANSER Part No. 575 300 000

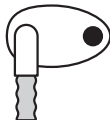

- **Suction cup**
E.g. JANSER Part No. 570 930 000



- **Rubber mallet**
E.g. JANSER Part No. 262 467 000



- **Double-handed pressure roller**
SPM Part No. OUTRMOO2

2. INSTALLING CORNER PROTECTORS

2.1 CORNER PROTECTORS ON ALUMINIUM CORE

SPM CORNEA, CORNEAFLEX and CAPCORN models are corner protectors consisting of a PVC profile mounted on an aluminium core.

The product's appearance is enhanced by end-caps at the top and bottom of the protector.

These protectors must be screwed to the wall. The table below shows the installation techniques to be used for the various wall surfaces found in the building industry.

TYPE OF WALL	INSTALLATION PROCEDURE
Wall with wooden studs	Woodscrews, 5 x 40 mm
Metallic structures	Self-tapping screws, 5 x 40 mm
Plasterboard (single skin), hollow brick, hollow breeze block	Metallic expansion plugs, 5 x 50 mm
Plasterboard (double skin)	Metallic expansion plugs, 5 x 50 mm
Concrete walls	FISCHER-type plugs, 6 mm diameter, for 5 x 40 mm screws
Solid brick wall, old walls	FISCHER-type plugs, 8 mm diameter, for 5 x 40 mm screws
Hollow plaster tiles, cellular concrete	FISCHER-type plugs, 8 mm diameter, for 5 x 40 mm screws

2.1.1 CORNEA, CAPCORN AND 135° CORNEAFLEX CORNER PROTECTOR INSTALLATION PROCEDURE

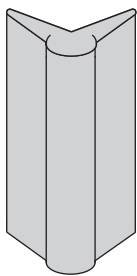

CORNEA

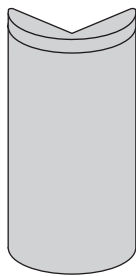

CAPCORN

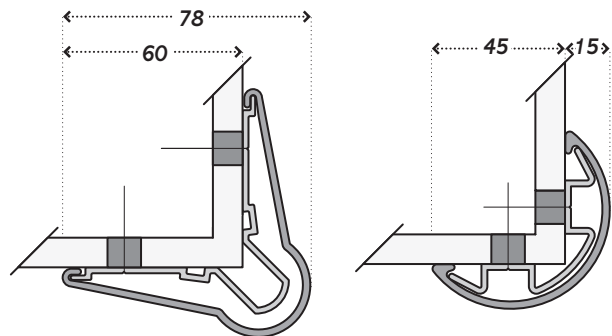

- Calculate the length of the aluminium core to be cut while deducting the dimensions of the end-caps from the overall length. The end-caps may be placed on the top and bottom of the protectors (fig.1).
- Cut the aluminium core to size using a circular saw or a hacksaw (fig. 2).

- The aluminium cores are pre-drilled.
- At the ends, check that the drilled holes are at a distance of 20 to 50 mm max. from the end of the core. If required, drill two 5 mm diameter holes through the core along the grooves with an offset between them to allow for fixing screws (fig.3).

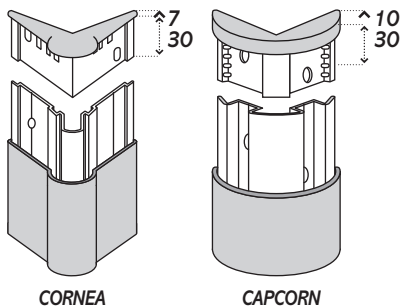

CORNEA

CAPCORN

fig.1

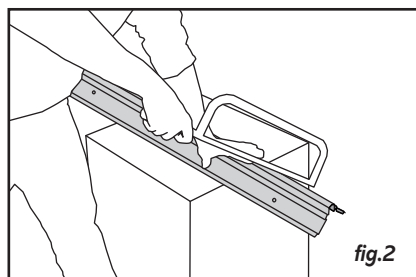

fig.2

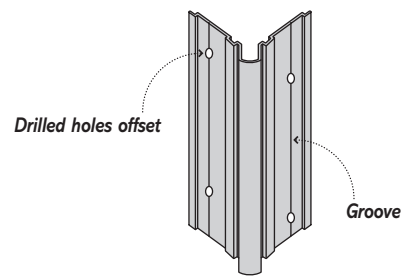
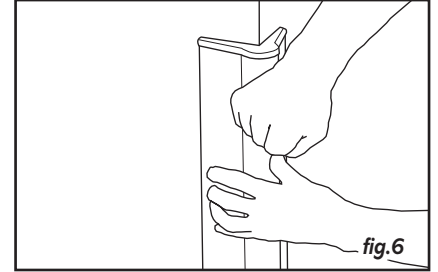
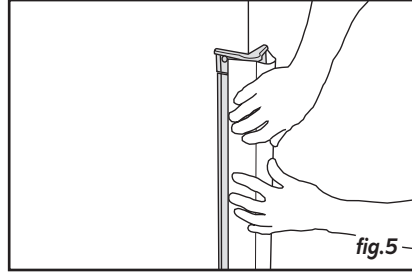
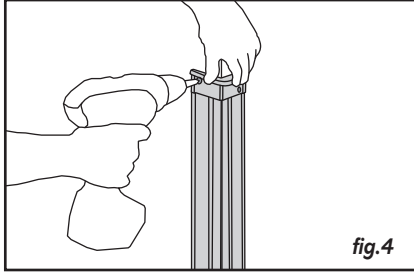

fig.3

- Place the end-caps against the wall with the aluminium core.
- Mark end-cap and aluminium core screw holes using a pencil.
- Drill the wall, fit plugs and screw to wall starting with the lower end-cap, the aluminium core and the upper end-cap (fig.4).



- Lastly, fit the PVC profile by positioning one end of it on the aluminium core in abutment with the end-caps (fig.5).
- Then snap-fix the other end of the PVC profile by tapping it home (fig.6).

2.1.2 VARIABLE ANGLE CORNEAFLEX INSTALLATION PROCEDURE

CORNEAFLEX corner protectors are installed using two separate aluminium cores and installed full height (floor to ceiling).

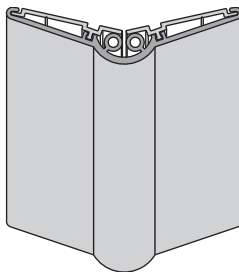

VARIABLE-ANGLE
CORNEAFLEX

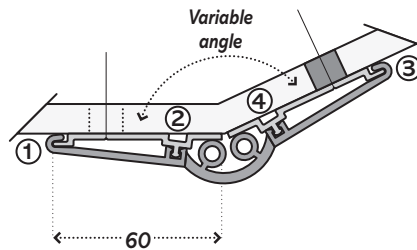

- After drilling the cores, place one core against the wall and mark out the mounting holes.
- Drill and screw-plug the holes and then mount the core onto the wall.
- Next, snap-fit the PVC profile to both mounting cores and position the whole assembly against the wall.
- Mark out the position for the second core.
- Remove the assembly. Replace the core against its marks and mark out the mounting holes.

- Drill and screw-plug the holes and then mount the second panel onto the wall.
- Next, snap-fit on the PVC profile, starting with the edge ①, and then the first snap attachment on the same side ②. Then snap-fit on the second edge ③ and the second snap attachment ④.
- Use rubber mallet to apply pressure to ensure aluminium is attached correctly to PVC profile.

■ 2.2 SELF-ADHESIVE CORNER PROTECTORS

2.2.1 PROFILA 30 AND 50, PROTECTA 2 AND PROFIL'INOX 30 AND 50 CORNER PROTECTOR INSTALLATION PROCEDURE

The SPM PROFILA and PROTECTA2 models are corner protectors in the form of a 2 mm thick PVC profile.

The SPM PROFIL'INOX 30 and 50 models are corner protectors in the form of a 1 mm thick stainless steel profile.

These protectors are mounted directly onto the wall surfaces using SPM mastic glue.

Self-adhesive foam strips are fitted to both ends in order to hold the corner protector in place while the glue dries (tack time). These adhesive foam strips alone do not provide permanent support.

- Apply the SPM mastic glue to the surface of the profile as shown in the drawing below (fig.1).
- Peel the protective films from the adhesive foam strips (fig.2).
- Place the corner protector against the wall.
- Press down hard (with a roller) all over the entire surface of the PVC or stainless steel extruded section.
- Clean off any excess glue with a rag and hot water.

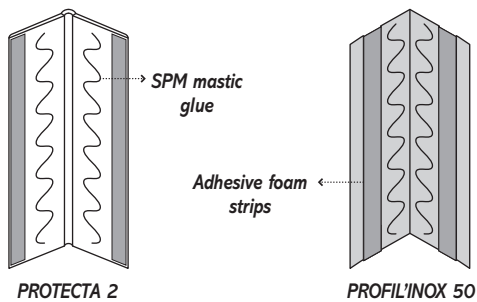

fig.1

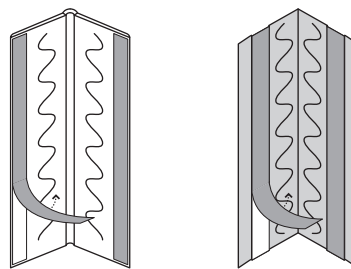
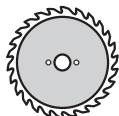

fig.2

— HANDRAILS

1. TOOLS REQUIRED



- **Circular saw with a fine-toothed carbide blade for aluminium and PVC for straight cuts and ripping**

E.g. JANSER-type KSS 300, Part No. 240 996 000



- **Rubber mallet**

E.g. JANSER Part No. 262 467 000



- **Measuring tape and pencil**

E.g. JANSER Part No. 262 481 000

or

- **Laser**

E.g. JANSER LL120 Part No. 270 580 000



- **Level & ruler**

E.g. JANSER NIV'O Part No. 110 145 000

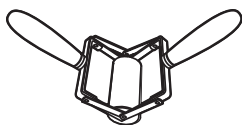

- **Double-handed pressure roller**

SPM Part No. OUTRMOO2



- **Drill and screwdriver**

E.g. JANSER Part No. 575 300 000



- **Suction cup**

E.g. JANSER Part No. 570 930 000

- **Rigid PVC adhesive, e.g., TANGIT - U**

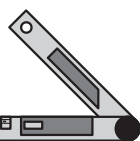

- **LOCTITE- type glue**

- **Angle finder**

E.g. BOSCH Part No. DWM 40L



- **Self-tapping 4.2 x 19 mm Phillips cylindrical head screw DIN 7505M**

E.g. FABORY Part No. 311 200 420 19

- **Allen key, 2.5 mm A/F**

2. INSTALLING HANDRAILS

The table below shows the installation techniques to be used for the various wall surfaces found in the building industry.

These techniques are applicable to all SPM handrail types.

TYPE OF WALL	INSTALLATION PROCEDURE
Walls with wooden studs	Woodscrews, 5 x 40 mm
Metallic structures	Self-tapping screws, 5 x 40 mm
Plasterboard (single skin), hollow brick, hollow breeze block	Metallic expansion plug, 5 x 50 mm
Plasterboard (double skin)	Metallic expansion plug, 5 x 50 mm
Concrete walls	FISCHER-type plugs, 6 mm diameter, for 5 x 40 mm screws
Solid brick wall, old walls	FISCHER-type plugs, 8 mm diameter, for 5 x 40 mm screws
Hollow plaster tiles, cellular concrete	FISCHER-type plugs, 8 mm diameter, for 5 x 40 mm screws

3. INSTALLATION PROCEDURE

The procedure below shows the quickest and simplest way to install SPM handrails. In principle, there are two major stages:

- Cutting the profile to length: this procedure is common to all SPM handrail models.
- Preparing and mounting the handrails: this procedure is specific to each model.

At least two people are needed to install SPM handrails.

3.1 CUTTING ALUMINIUM AND PVC PROFILES TO LENGTH

■ Measure each section of wall in order to cut and prepare the lengths of handrail before installation.

■ At each end of the handrail, allow a clearance of 30 mm between the end of the handrail (with its wall return) and the edge of the wall or doorframe. This 30 mm clearance, which is the distance the accessory penetrates into the profile, allows the wall return to be removed if it has to be replaced.

■ Based on this measurement, use the table below to calculate the cutting lengths of aluminium and PVC profiles (aluminium profile only in the case of PERFORMER handrails).

■ The table below shows the allowances to be subtracted (or added) to the aluminium or PVC profiles, based on the various wall return and internal/external angle pieces to be used.

HANDRAIL	END-CAP	WALL RETURN	INTERNAL/EXTERNAL ANGLE PIECE
ESCORT 40 Aluminium & PVC	-22 mm	-82 mm	Internal: -122 mm, External: -2 mm
STARLINE 90 Aluminium & PVC	-17 mm	-85 mm	Internal: -132 mm, External: -2 mm
PERFORMER 2 Aluminium	-16 mm	-86 mm	External: +23 mm
PERFORMER 2 PVC	-7 mm	-106 mm	External: +3 mm

■ Once the lengths of the aluminium and PVC profile have been calculated, cut the profiles to length using a circular saw with a suitable blade (ideally, a fine-toothed blade in order to give a smooth edge).

For a better appearance, saw the aluminium and PVC profiles to length while they are snap-fixed together.

Example of measurements for ESCORT 40 profile

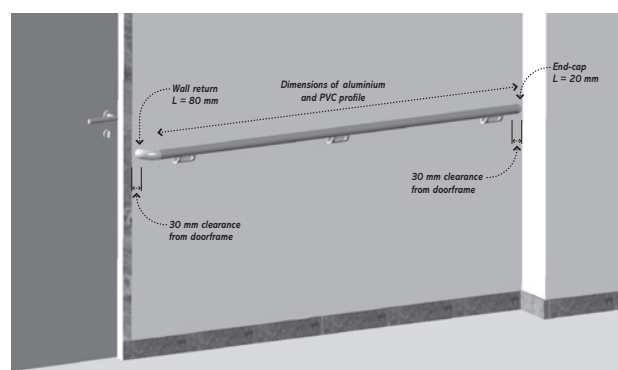

ESCORT 40

3.2 PREPARING ESCORT 40 HANDRAILS

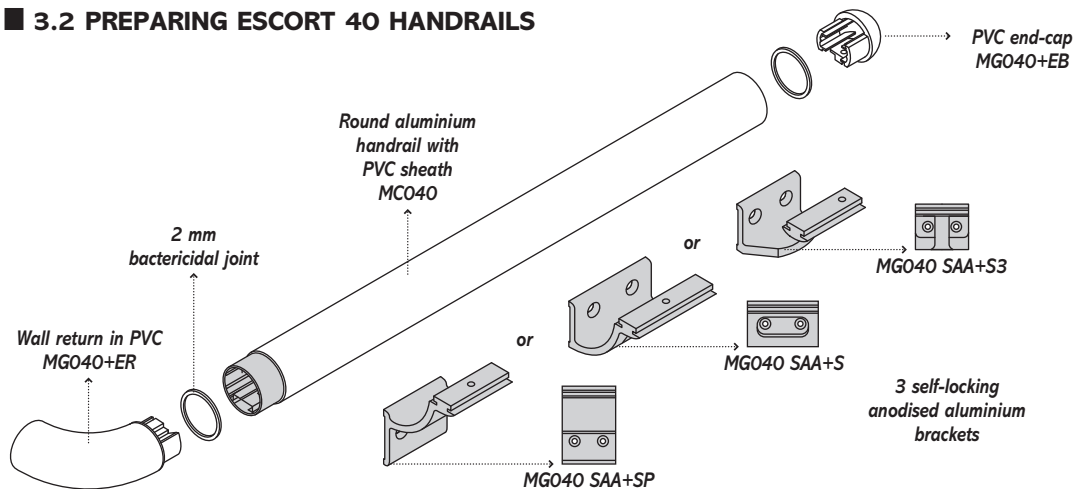

ESCORT handrails are delivered with the PVC sheath already snap-fixed to the aluminium profile.

- Slide the brackets into the slot of the aluminium profile.
- For end brackets, use spacing for one bracket between the edge of the profile and the end bracket.
- Now set the brackets at 1 200 mm intervals. Where heavy use is likely, and for lighter wall surfaces, e.g., plasterboard, use 800 mm intervals.
- For short handrail lengths, use at least two brackets set at even intervals.
- Now clamp the brackets to the aluminium profile using a 2.5 mm Allen key (fig.1).

- Next, insert the accessory fittings (end-caps, wall returns, joints, etc) and lock them with the pre-fitted screws so that they expand and hold the accessories firmly.
- Finally, cut the closers to the required lengths and snap-fix them into the profile slot.

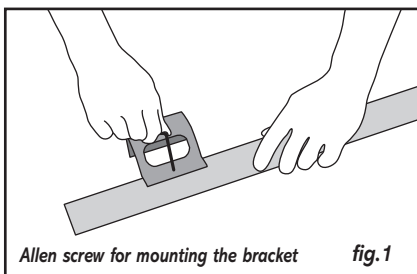
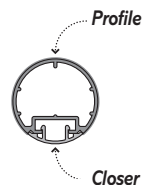

3.3 MOUNTING ESCORT 40 HANDRAILS

- Once the lengths of handrail have been prepared, together with their wall returns, end-caps, brackets and closers, the handrails may be mounted to their respective sections of wall.
- For a handrail height of 900 mm above floor level, use a pencil (or a laser) to draw, at each end of the wall section, a mark at a height of 845 mm (for MGO40+S and MGO40+S3 brackets) or 810 mm (for

MGO40+SP brackets).

- Take care to draw these marks in such a way as to coincide with the bracket mounting holes (draw lines about 50 mm long, starting at a distance of 210 mm from the edge of the wall for ends with wall returns, or 150 mm for ends with end-caps).

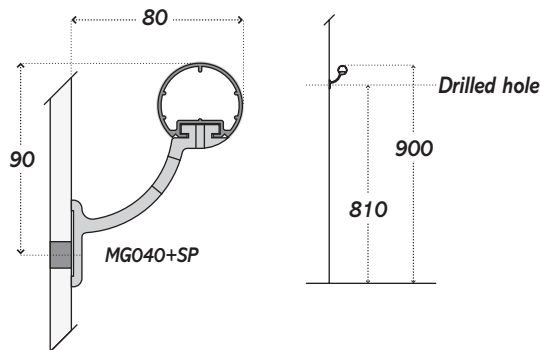
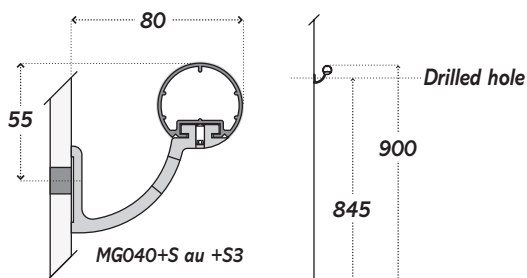

- Next, hold the handrail against the wall, leaving a space of 30 mm with respect to the edge of the wall, and place the holes drilled in the brackets over the marks.
- Use a spirit level to check the handrail for horizontal and then mark the holes to be drilled for each bracket on the wall.
- Now use a suitable drill bit to drill into the wall. The diameter of the drilled hole will vary with the type of wall (see the handrail installation

procedures table above (page 25).

- When drilling in clean environments, we recommend the use of a suction cleaner held immediately below the drill bit in order effectively to collect all the dust.
- Once all the holes have been drilled, mount the handrail brackets to the wall, starting with the two end brackets.

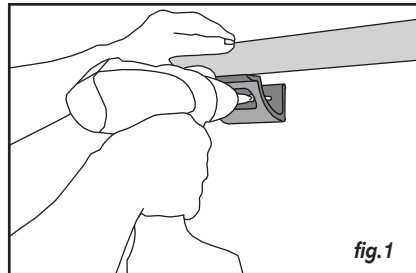
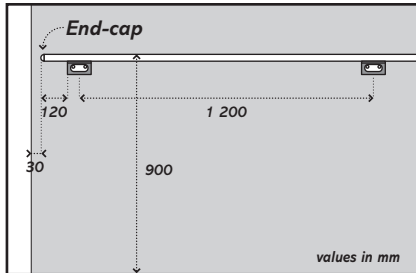
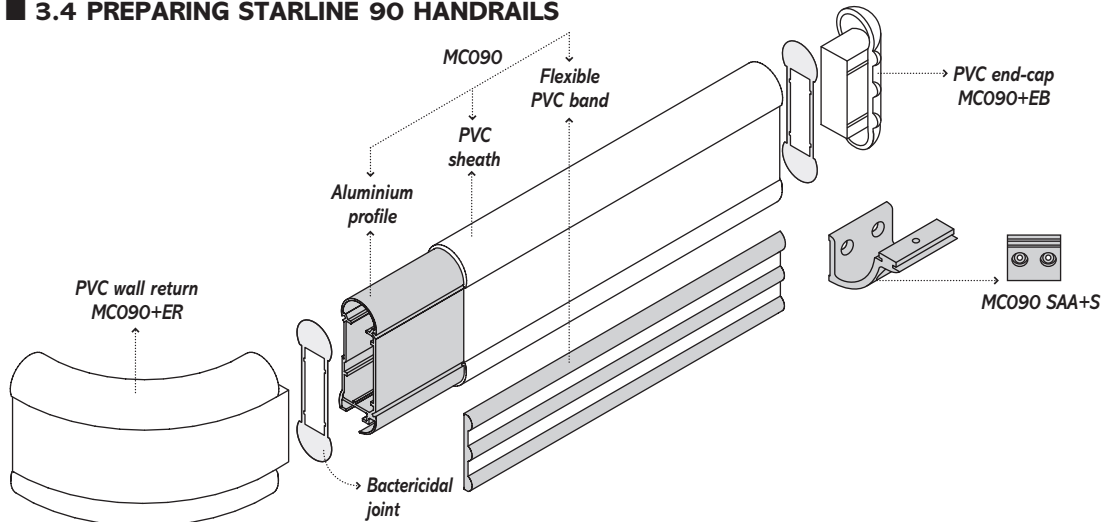

fig.1

STARLINE 90

■ 3.4 PREPARING STARLINE 90 HANDRAILS



- Slide the brackets into the slot of the aluminium profile.
- For end brackets, use spacing for one bracket between the edge of the profile and the end bracket.
- Now set the brackets at 1 200 mm intervals. Where heavy use is likely, and for lighter wall surfaces, e.g., plasterboard, use 800 mm intervals.
- For short handrail lengths, use at least two brackets set at even intervals.
- Now clamp the brackets to the aluminium profile using a 2.5 mm Allen key (fig.2).
- Assemble the aluminium profile and the accessories using a self-tapping 4.2 x 19 mm screw or a rivet as per diagrams below (fig.3.1 and 3.2).
- Position screw or rivet 10 mm in from the ends of the profile.
- For anodised and PVC sheathed versions, stick the flexible, pre-glued PVC band along the whole length of the profile and its accessories

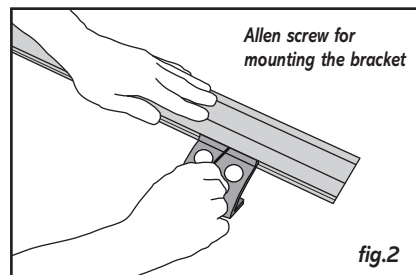

fig.2

(fig.4).

- Press this band down hard all along its length.
- Reinforce bonding of ends of band to wall returns using LOCTITE-type glue.

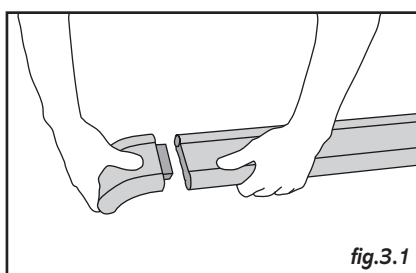

fig.3.1

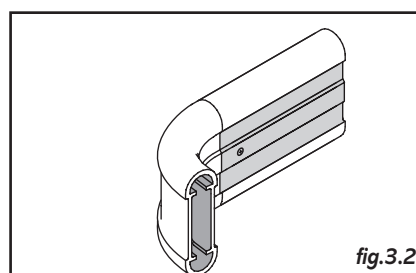

fig.3.2

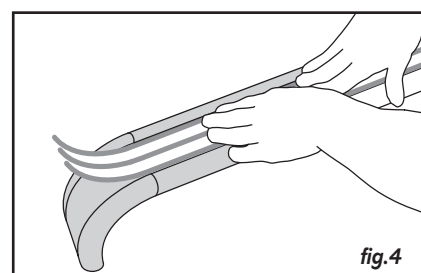
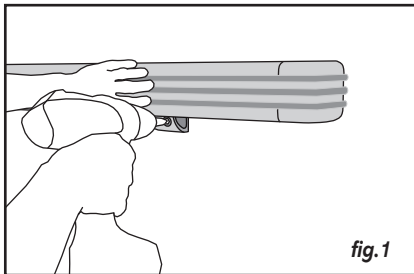
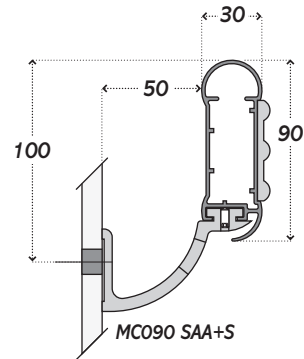

fig.4

3.5 MOUNTING STARLINE 90 HANDRAILS

- Once the lengths of handrail have been prepared, together with their wall returns, end-caps and brackets, the handrails may be mounted to their respective sections of wall (fig.1).
- For a handrail height of 900 mm above floor level, use a pencil (or a laser) to draw, at each end of the wall section, a mark at a height of 800 mm for MC090 SAA+S brackets.
- Take care to draw these marks in such a way as to coincide with the bracket mounting holes (draw lines about 50 mm long, starting at a distance of 185 mm from the edge of the wall for ends with wall returns, or 115 mm for ends with end-caps).
- When the marking out of each wall section is complete, mount the handrail to the wall using the method shown for the ESCORT 40 rails (See paragraph 3.3 on page 27).



PERFORMER

3.6 PREPARING PERFORMER HANDRAILS

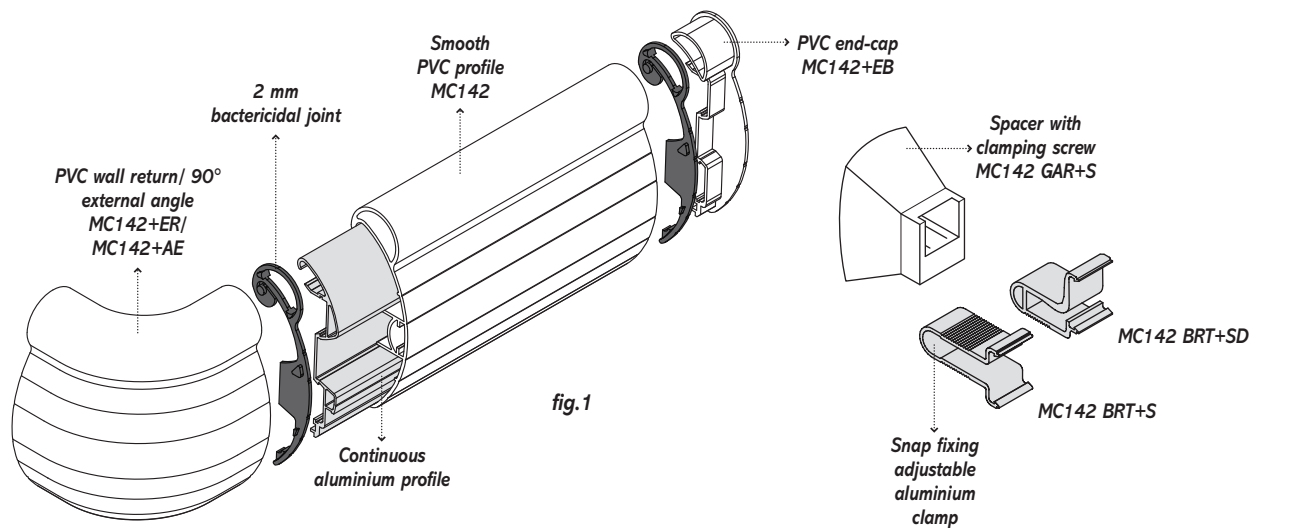

1st CASE:

The section of handrail is mounted with at least one end-cap.

- First, snap-fix the PVC profile to the aluminium profile.
- Fit the bactericidal joint on the end-cap.
- Fit the end-cap into the PVC profile while checking the seal is correctly positioned.
- Bond the end-cap to the PVC profile using PVC glue. Apply glue to both upper and lower parts of the end-cap.
- Fit the accessory to the other end.

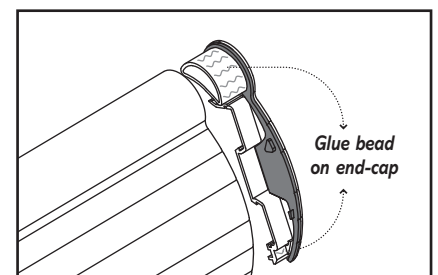

■ 2nd CASE:

The section of handrail is mounted with two wall returns.

- Begin by placing the wall return on one side only of the aluminium profile.
- Check wall return is perpendicular to the aluminium profile.
- Attach the accessory using a self-tapping screw (4.2 x 19 mm) placed 10 mm from the end of the accessory (fig.1).
- Fit the bactericidal joint making sure the locators holding the joint in place are properly inserted in the accessory slots.
- Then snap-fix the PVC profile onto the aluminium rail and slide it against the joint making sure the bosses fit into the interstices.
- Fit the joint and accessory on the other side of the rail and attach the accessory.

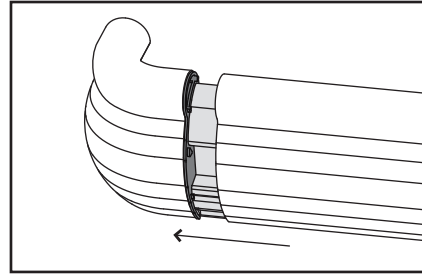

■ In both cases, once the accessories have been fitted:

- Lock the assembly using a self-tapping screw at both ends of the aluminium profile (fig.2).
- Lastly, fit the snap-fixing clamps to the aluminium profile (fig.3).

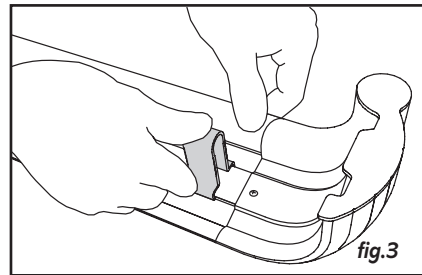
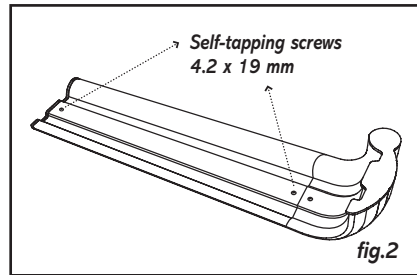
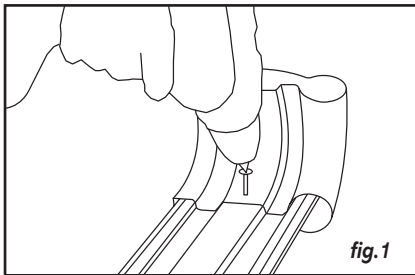

■ 3.7 MOUNTING PERFORMER HANDRAILS

■ For a handrail height of 900 mm above floor level, position the mounting spacers at a height of 824 mm for MC142BRT+S spacers and 804 mm for MC142BRT+SD spacers.

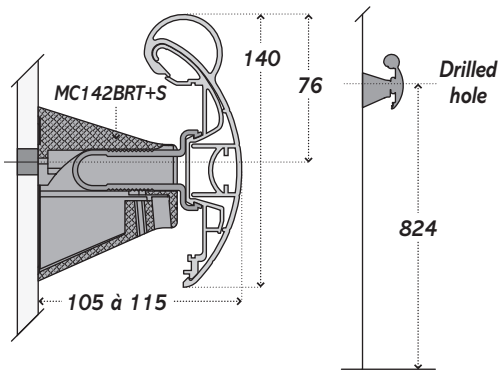

MC142BRT+S SPACER

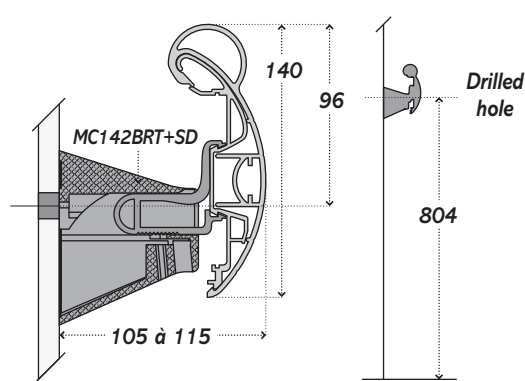

MC142BRT+SD SPACER

- Mark out the wall using a pencil and rule, or a laser.
- Position the outside spacers 230 mm in from the ends of the wall section.
- Drill and plug the wall and then start the screw in the plug. Hold the spacer against the wall whilst sliding it onto the screw and then tighten the screw (fig.4).
- Now set the spacers at 1200 mm intervals. Where heavy use is likely, and

- for lighter wall surfaces, e.g., plasterboard use 800 mm internals (fig.4).
- Position the handrail onto its mounting spacers by moving the snap-fixing sliding clamp as required (fig.5).
- Adjust the gap between the handrail and the wall as required and then tighten the screw underneath using a 3 mm Allen key (fig.6).

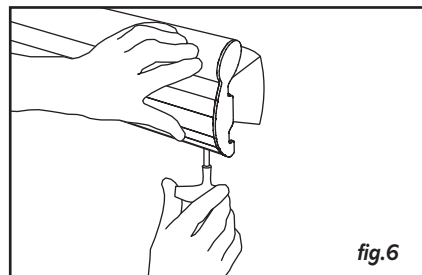
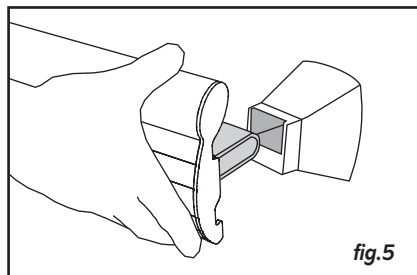
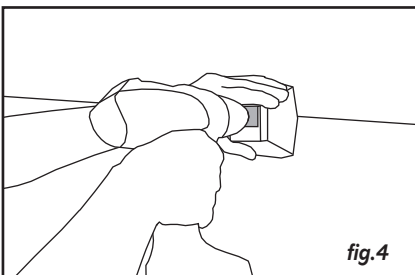

4. INTERNAL, EXTERNAL AND MADE-TO-MEASURE ANGLES

List of angles available for SPM handrails:

HANDRAIL	INTERNAL ANGLES	EXTERNAL ANGLES	MADE-TO-MEASURE ANGLES
ESCORT 40	Available	Available	Available from 90 to 165°
STARLINE 90	Available	Available	Available from 90 to 160°
PERFORMER 2	Unavailable	Available	Unavailable

■ The angle of each corner must be measured beforehand, in situ, using an angle-finder.

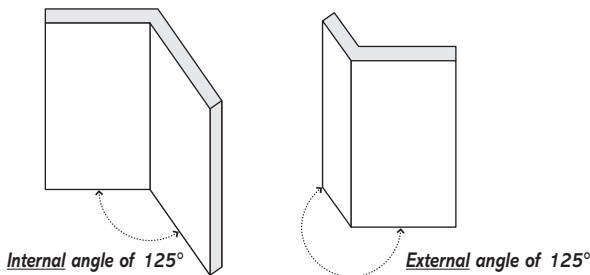

We recommend using the following procedure to obtain a perfect fit between the handrail and the angle piece whilst ensuring the angle piece is set centrally over the corner of the wall:

- Mount the handrail onto one end of the angle piece and tighten the mounting screw (or drill and pop-rievet in the case of STARLINE 90 or PERFORMER handrails).
- At the other end of this angle piece, insert a 500 mm length of handrail. This length is just for use as a template and must not be permanently attached to the angle piece.
- Mount the brackets onto the handrails (with two brackets on the template piece).
- On the first wall section, mark out the mounting height for the handrail.
- Position the assembly against the wall over the height marks. Now hold the brackets on the template piece against their wall section. This method makes it easy to hold the assembly steady.
- Mark the bracket mounting holes through onto the wall (using a spirit level to check the assembly for horizontal).
- Rest the assembly on the ground and remove the template piece.

- Drill and plug the first wall section, i.e., the handrail side, not the template-piece side.
- Assemble and mount the handrail and its brackets to the angle piece, in place of the template-piece.
- Position the assembly against the wall, following marking out.
- Now temporarily attach the first section of handrail to the wall. One person should attach the handrail, starting with the outside brackets, whilst the other person supports the other section of handrail to avoid breaking the angle piece.
- Next, mark out the mounting holes for the handrail not yet attached.
- Once this marking out is complete, remove the assembly from the wall by unscrewing the brackets for the handrail attached earlier.
- Drill and plug the second wall section.
- Reposition the assembly and mount the first section of handrail, and then the second section, to their respective walls.

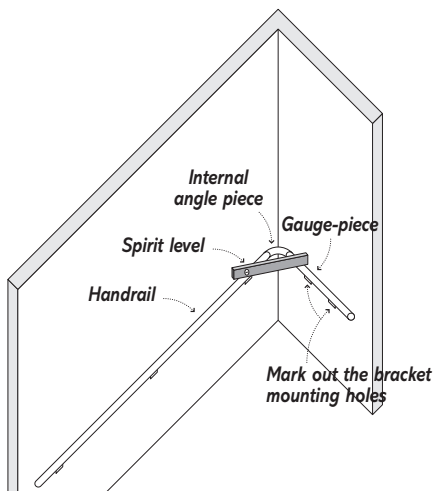

5. JOINTING HANDRAILS

Jointings are used to ensure a strong and smooth joint between two straight lengths of handrail.

ESCORT 40 and STARLINE 90 handrail jointings consist of two parts that are quick and easy to install:

- A 100 mm long assembly wedge provides a strong joint between the handrails.
- A jointing block for correctly aligning the handrail.

For PVC sheathed ESCORT 40 and STARLINE 90 handrails, offset the ends of the aluminium profile and the PVC sheathes in order to hide any gaps.

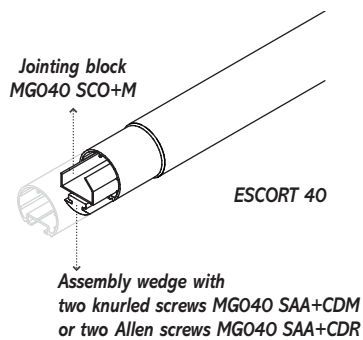
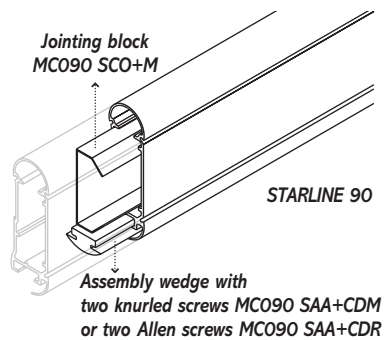

The jointing between two lengths of PERFORMER handrails consists of just one piece that ensures both the alignment and strength of the jointing.

The piece is attached to the aluminium rail by two hex-headed screws of 5 mm diameter.

With PERFORMER handrails, offset the ends of the aluminium and PVC profile to hide any gaps.

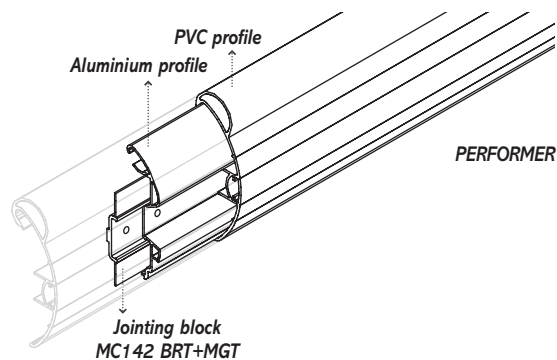

6. SHIM

Where the wall surface is uneven, the brackets for ESCORT 40 and STARLINE 90 may be adjusted against the wall by the use of 10 mm adjusting shims. These shims are fitted behind the brackets.

Shim MGO40 SCO+CAL (for ESCORT 40)
Shim MC090 SCO+CAL (for STARLINE 90)

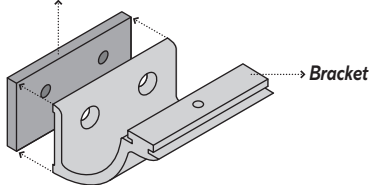

7. INSTALLING HANDRAILS ON STAIRCASES

4

Where staircases have landings, use ESCORT 40 handrails.

STAIRCASES WITH WINDING LANDINGS

- This installation uses slope link pieces and external angle pieces at each landing.
- Slope link pieces are made to measure (between 90 and 165°). The slope for each staircase must first be measured with an angle-finder.
- The slope link piece is sleeved over the handrail and then clamped permanently with a pre-fitted screw.

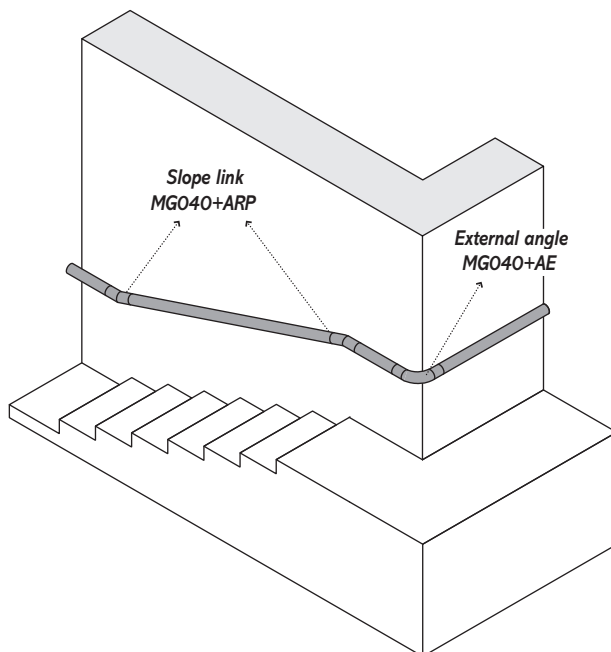

STAIRCASE WITH A STRAIGHT LANDING

- This installation uses slope link pieces and angled slope link pieces at each landing.
- The angled slope link consists of a separate angle piece and sleeve.
- Both pieces are attached to the handrail with a pre-fitted screw.
- The angle piece and the sleeve are joined together with an adhesive such as TANGIT-U for rigid PVC. This must be done at the time of installation in order to align the two handrail sections correctly.

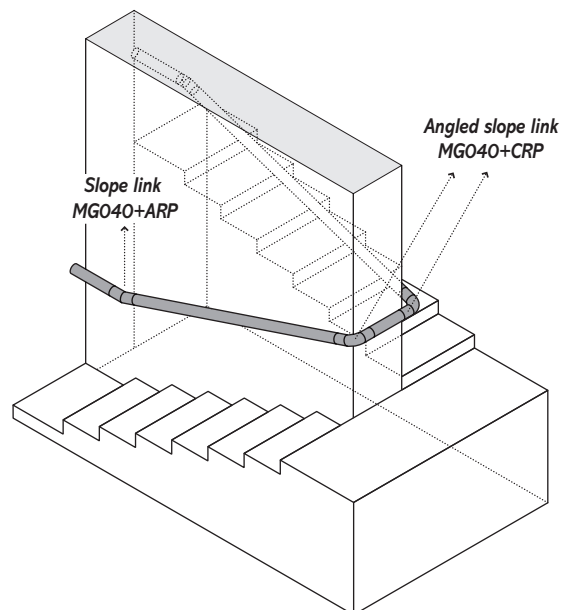

8. INSTALLING HANDRAILS WITH SERVICE DUCT KIT

Where service duct is installed, it may be necessary to provide a removable handrail section where access is required to the duct.

8.1 ESCORT

For ESCORT 40 handrails, service duct kit is provided in-situ by cutting the profile to the length of the access gate using 45° mitred cuts.

SERVICE DUCT KIT FOR THE ESCORT 40 HANDRAIL:

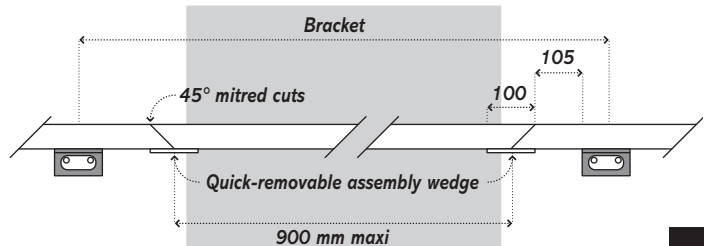

8.2 STARLINE 90

For STARLINE 90 handrails, SPM can provide a 900 mm ready-to-install kit (other lengths on request).

SERVICE DUCT KIT FOR STARLINE 90 HANDRAILS:

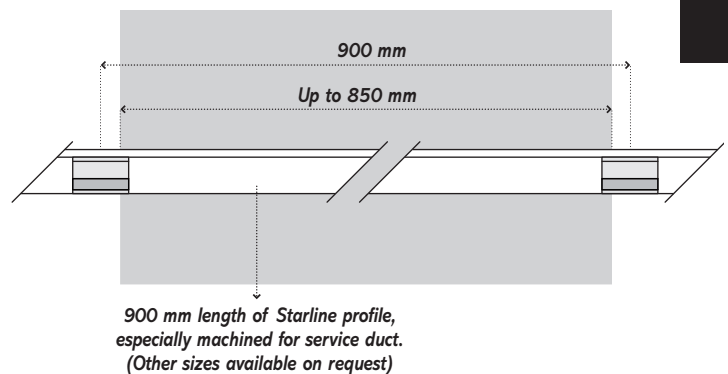
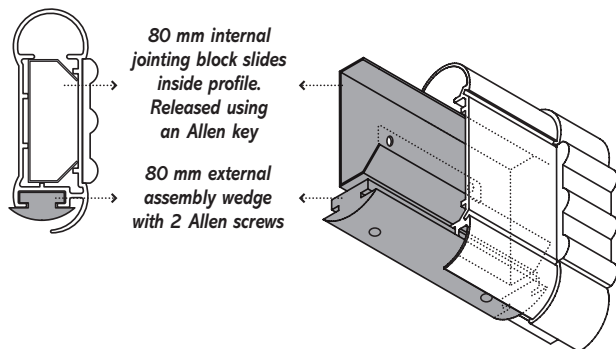

8.3 ASSEMBLY USING A QUICK-REMOVABLE BRACKET

- For ESCORT 40 or STARLINE 90 service duct gates longer than 900 mm, it will be necessary to provide a quick-removable bracket at the service duct access gate.

- The quick-removable bracket comes with an assembly wedge (MG040 SAA+SDE for ESCORT 40 or MC090 SAA+SDE for STARLINE 90) that can be clamped or unchanged into the groove in the aluminium profile using a 5 mm Allen key.

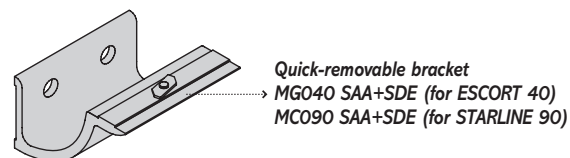

4

9. INSTALLING CURVED HANDRAILS

Curved handrails may be installed using ESCORT 40 or STARLINE 90 handrails.

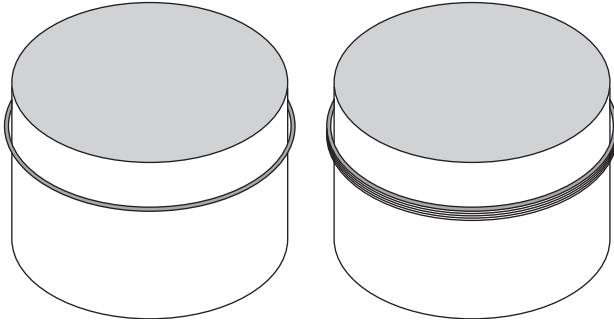

The available curvature limits using the different handrails are shown below.

PRODUCT	MINIMUM CURVATURE RADIUS	MAXIMUM CURVATURE RADIUS
ESCORT 40 with PVC sheath or wood effect	2 m	12 m
ESCORT 40 anodised or coated	0,4 m	12 m
STARLINE 90 with PVC sheath	3 m	12 m
STARLINE 90 anodised, wood effect or coated	0,4 m	12 m

For curvature radii below 2 metres, the curved handrails are mounted on special reduced brackets (width).

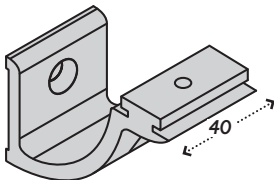

MG040 SAA+SR (for ESCORT 40)
MC090 SAA+SR (for STARLINE 90)

Where curved handrails are installed in a run with straight handrails, the curved part is terminated with straight sections at each end in order to achieve a smooth junction.

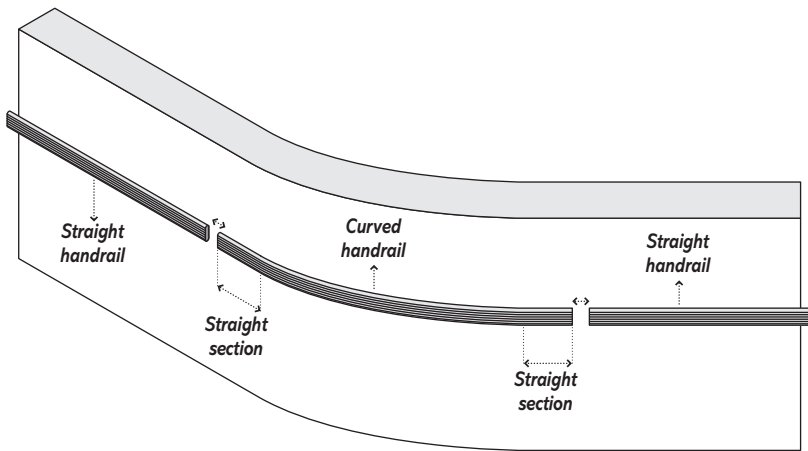

Curved handrails are manufactured using templates manufactured in-situ. The procedure below is used to establish the size of the template:

- Draw a reference line on the floor whose X-X axis is a line tangential to the radius (for convex curves) or the line of the chord across the curved section (for concave curves).
- Now draw several lines in towards the curve of the wall, at 200 mm intervals, perpendicular to the X-X axis.
- Now draw up a table showing the x and y values for each line.

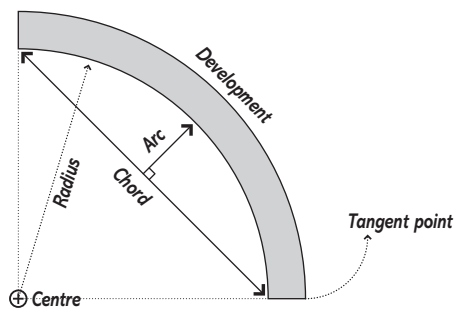
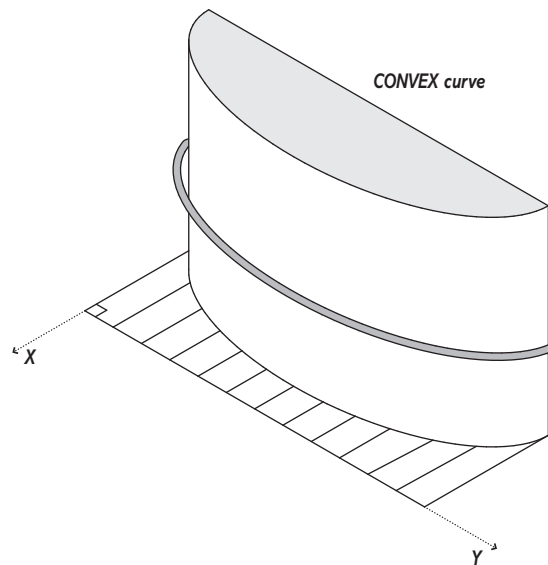
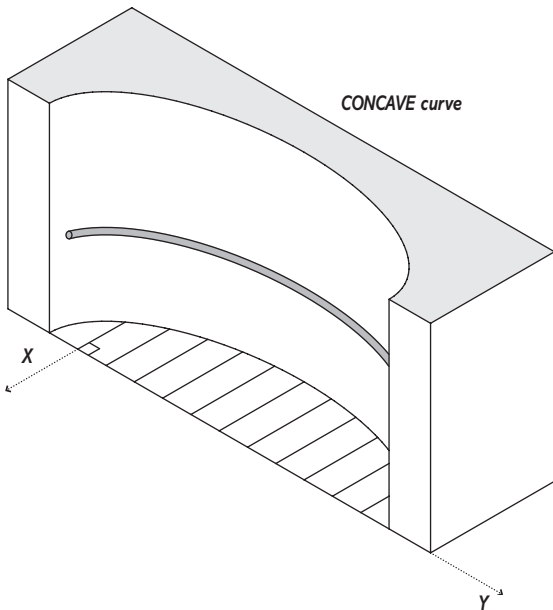

ASIA: Gerflor Asia
Tel: +852 9222 6355 - Fax: +852 3006 1449
e-mail: gerflorasial@gerflor.com

AUSTRALIA/NEW ZEALAND: Gerflor Australasia Pty. Ltd
Australia Tel: 1 800 060 785 - New Zealand Tel: 0 800 630 119
e-mail: gerflor@gerflor.com.au

AUSTRIA/SWITZERLAND: Gerflor GmbH
Tel: +43 (0)72 29/70 800-0 - Fax: +43 (0)72 29/70 800-218
e-mail: austria@gerflor.com - switzerland@gerflor.com

BELGIUM/LUXEMBURG: Gerflor Benelux
Tel: +32 (0)3 766 42 82 - Fax: +32 (0)3 766 29 14
e-mail: gerflorbelgium@gerflor.com

CANADA: Gerflor International
Tel: +1 450 538 9828 - Fax: +1 450 538 9827
e-mail: gerflorcanada@gerflor.com

CHINA: Gerflor China
Tel: +86 21 6357 8818 - Fax: +86 21 6357 8998
e-mail: gerflorchina@gerflor.com

FINLAND: Gerflor Oy
Tel: +358 (0) 10 6 17 5150 - Fax: +358 (0) 10 617 5152
e-mail: info@gerflor.fi

FRANCE: SPM
Service Clientèle:
Tel: +33 (0)5 34 39 40 40
Fax: +33 (0)5 34 39 40 50
e-mail: service.clientele@spm.fr

GERMANY: Gerflor Mipolam GmbH - Kunden-Service
Tel: +49 (0)22 41-25 30 131 - Fax: +49 (0)22 41-25 30 100
e-mail: kundenservice@gerflor.com

IRELAND: Gerflor Ltd
Tel: +353 (0) 42 966 1431 - Fax: +353 (0) 42 966 1759
e-mail: gerflorirl@gerflor.com

ITALY: Gerflor S.p.A.
Tel: +39 02 90 78 60 12 r.a. - Fax: +39 02 90 42 74 84
e-mail: gerfloritalia@gerflor.com

LATIN AMERICA (Brazil): Gerflor América Latina
Tel: +55 11 38 48 20 20 - Fax: +55 11 38 48 20 23
e-mail: gerflor@gerflor.com.br

MIDDLE EAST: Gerflor Middle East
Tel: +966 3 847 1779 - Fax: +966 3 847 1781
e-mail: gerflorME@gerflor.com

NETHERLANDS: Gerflor BV
Tel: +31 (0)40 266 17 00 - Fax: +31 (0)40 257 46 89
e-mail: gerflorNL@gerflor.com

OTHER COUNTRIES: Gerflor International
Tel: +33 (0)4 74 05 40 00 - Fax: +33 (0)4 74 05 03 13
e-mail: gerflorcontract@gerflor.com

POLAND: Gerflor Polska Sp z o.o
Tel: +48 61 823 34 01 - Fax: +48 61 823 34 33
e-mail: info@gerflor.pl

PORTUGAL: Gerflor Iberia, SA
Tel: +351 21 843 95 49 - Fax: +351 21 846 55 44
e-mail: gerflorportugal@gerflor.com

RUSSIA: Gerflor Moscow Office
Tel: +7 495 430-86-54 / 65 - Fax: +7 495 430-85-46
e-mail: gerflorrus@mspk.east.ru

SCANDINAVIA: Gerflor Scandinavia
Tel: +47 64 95 60 70 - Fax: +47 64 95 60 80
e-mail: gerflorscand@gerflor.no

SPAIN: Gerflor Iberia, SA
Tel: +34 91 653 50 11 - Fax: +34 91 653 25 85
e-mail: gerfloriberia@gerflor.com

UNITED KINGDOM: Gerflor Ltd
Tel: +44 (0)1926 622 600 - Fax: +44 (0) 1926 401 647
e-mail: contractuk@gerflor.com

USA: Gerflor North America
Tel: 877 GERFLOR (437 3567) - Fax: 847 394 3753
e-mail: info@gerflorusa.com



Health
& Safety



ISO 14001



Recycling



Life Cycle
Analysis