

IMPACT



WALL PROTECTION RAILS - 200/120/60 MM HIGH

Applications

This horizontal protection system features contoured design to bring you the perfect combination of impact resistance and sheer good looks. Fitted at one or two levels, it protects walls exposed to intensive wheeled traffic in corridors, entrances and storage areas (hospitals, clinics, retirement homes, laboratories, hotels, restaurants, schools, department stores).

Specification

- Description : curved wall protection rail (Impact 200/120 or 60 as manufactured by SPM) from smooth and antibacterial PVC achieving Bs2d0 fire rating with solid colour. PVC profile projects 30 mm, is 200/120 or 60 mm high and 3 mm thick. It provides a smooth surface finish with decorative grooves and snap-fixes onto aluminium brackets or continuous aluminium rail (optional). A protective film is specified to minimise cleaning before acceptance. Finish is provided by end pieces, external and internal 90° angle pieces in smooth PVC and aluminium joint blocks.
- Environment: no heavy metals and no substance potentially subjected to any REACH restriction are used in its manufacture, nor PBT/

BPA. The calcium-zinc thermal stabilisation process is used. The emission level of volatile substance in inside air has been tested according to ISO 16000-6 and is very low (A+) according to the French regulation (23 March 2011 nr 2011-321 Decree and 19 April 2011 Order). 100% of the product are recyclable.

- Colour: selected by architects from manufacturer's standard range. The colours of accessories are the same as the profile.

- Installation method: recommended height of protection rail centreline 0.80 m above floor level for mid-level wall protection or on top of the skirting for low level wall protection. Snap-fixes onto aluminium brackets spaced at 0.75 m centres or continuous aluminium rail (optional).

NB: The end piece serves as the first clip.

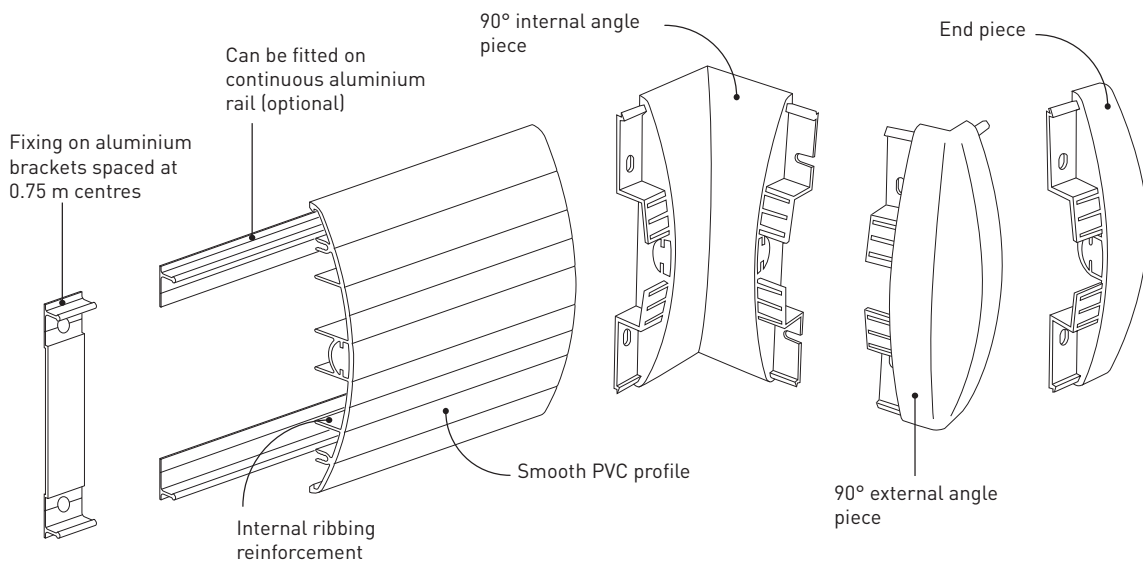

Impact 200/120
31 colours



Impact 60
5 colours*

*and 26 colours on request with
(Please consult us)

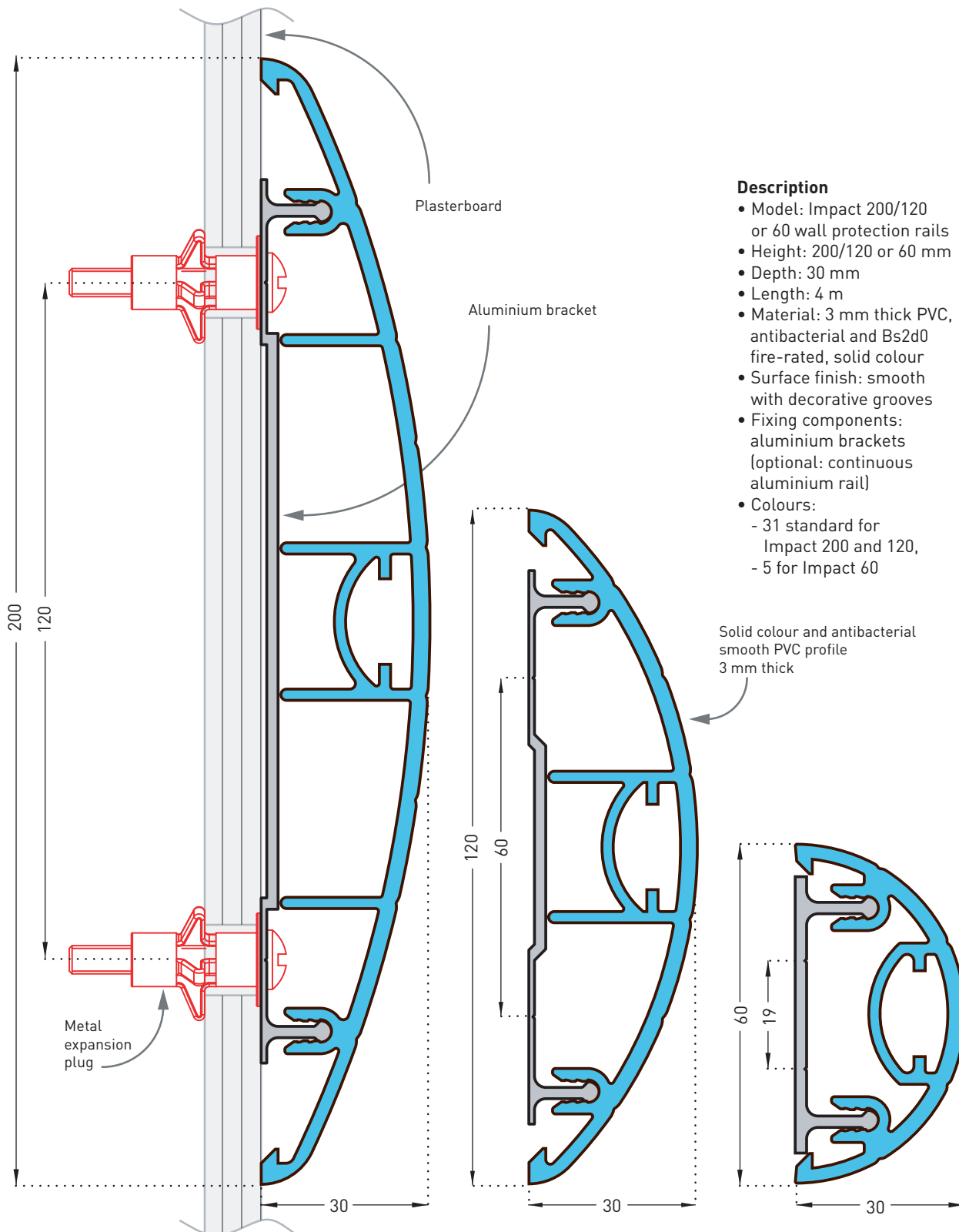

Description

- Model: Impact 200/120 or 60 wall protection rails
- Height: 200/120 or 60 mm
- Depth: 30 mm
- Length: 4 m
- Material: 3 mm thick PVC, antibacterial and Bs2d0 fire-rated, solid colour
- Surface finish: smooth with decorative grooves
- Fixing components: aluminium brackets (optional: continuous aluminium rail)
- Colours:
 - 31 standard for Impact 200 and 120,
 - 5 for Impact 60